



SERIE RO
Scambiatori di calore
ARIA/OLIO
AIR/OIL heat exchangers

SERIE RO



Il presente catalogo illustra gli scambiatori di calore della serie RO costruiti in acciaio e rame. Ogni scheda fornisce i dati tecnici relativi allo scambiatore impiegato per il raffreddamento di circuiti oleodinamici e ai ventilatori azionati da motore elettrico o idraulico.

Caratteristiche tecniche massa radiante:

Materiale: acciaio e rame
Pressione di esercizio: 15 bar
Pressione di collaudo: 22 bar
Temperatura massima di esercizio: 120°C

Consultare IRA RADIATORI per ambienti particolarmente aggressivi

INSTALLAZIONE

Lo scambiatore deve essere installato in modo tale da evitare la presenza di ostacoli alla circolazione dell'aria, rispettando la distanza minima dalla parete (1/2 diametro ventola) in modo da assicurare il naturale flusso dell'aria di raffreddamento. Può essere montato sia in posizione orizzontale che verticale.

Gli scambiatori di calore aria/olio RO sono normalmente utilizzati per il raffreddamento di circuiti oleodinamici e installati sulle linee di ritorno, devono essere protetti da urti e vibrazioni meccaniche mediante supporti elastici e collegati all'impianto mediante tubi flessibili.

Per evitare danni che brusche variazioni di portata o eventuali colpi d'ariete o pulsazioni continue arrecano agli scambiatori.

FLUIDI COMPATIBILI

- Oli minerali

Per altri fluidi consultare IRA RADIATORI

MANUTENZIONE

Pulizia lato olio

Dopo aver smontato lo scambiatore effettuare la pulizia facendo circolare all'interno del radiatore un prodotto sgrassante compatibile con leghe d'acciaio. Effettuare un lavaggio con olio idraulico prima di ricollegare lo scambiatore all'impianto.

Pulizia lato aria

Eeguire questa operazione mediante aria compressa. Assicurarsi che la direzione del getto sia parallela alle alette per non danneggiarle. Se l'intasamento dello scambiatore è causato da un accumulo di olio o di grasso, la pulizia potrà essere effettuata con un getto di vapore o di acqua calda. Durante le operazioni di pulizia il motore elettrico dovrà essere convenientemente protetto.

SICUREZZA

Nell'utilizzo dello scambiatore occorre attenersi ad alcune importanti avvertenze:

- Non togliere le protezioni delle ventole
- Far eseguire i collegamenti elettrici a personale specializzato seguendo gli schemi allegati
- Le superfici esterne dello scambiatore potrebbero avere temperature molto elevate, occorre quindi prevedere nel montaggio adeguate protezioni o posizionamenti poco accessibili
- Non intervenire sul motore idraulico senza prima aver scollegato i tubi

- Temperatura ingresso olio: 80°C
- Temperatura ambiente: 40°C
- Ventilatore elettrico 12 Volt

Occorre calcolare il coefficiente di scambio termico espresso in KW/°C dividendo la potenza da dissipare, per la differenza di temperatura tra olio e ambiente:

$$8KW : 40 \text{ °C} (80\text{°C}-40\text{°C}) = 0,20 \text{ kW/°C}$$

Occorre valutare sui diagrammi di rendimento quale scambiatore a corrente continua esprime la potenza specifica risultante (0,20kW/°C) con una portata di 50 lt/1'.

ESEMPIO DI SCELTA DELLO SCAMBIATORE

Per effettuare la scelta dello scambiatore si procede secondo l'esempio seguente:

- Potenza da dissipare: 8 kW
- Portata olio ISO VG 46: 50 lt/1'



This catalogue describes RO SERIES COOLERS made of copper and steel.

Each data sheet provides the technical information about the heat exchanger used for cooling oil hydraulic system and about fans operated by electric or hydraulic motor

Core's technical specification:

Material: copper and steel

Working pressure: 15 bar

Test pressure: 22 bar

Max working temperature: 120°C

Please contact IRA for aggressive ambient

INSTALLATION

The heat exchanger should be installed in such a way that there should be no obstacles to the air flow, respecting the minimum distance from the wall (1/2 fan diameter) so as to ensure a natural flow of cooling air.

The cooler can be fitted in vertical and horizontal position. RO series coolers are normally used for cooling hydraulic circuits and installed on the return lines: they must be protected from impact and mechanical vibrations by support and must be connected to the circuit with flexible pipes. To prevent any damage caused by changes in flow, hammering and pulsations we recommend installing a by-pass valve.

COMPATIBLE FLUIDS

- Mineral oils

For other fluid consults IRA RADIATORI

MAINTENANCE

Cleaning oil side

After having dismantled the exchanger, carry out the cleaning procedure by circulating de-greasing substance inside the radiator compatible with steel. Wash with hydraulic oil before reconnecting the cooler.

Cleaning air side

Carry out this procedure using compressed air. Make sure that the direction of the jet is parallel to the fins so that they are not damaged.

If the blockage of the exchanger is caused by build up of oil or grease, cleaning can be carried out using a jet of steam or hot water.



During cleaning procedures the electric motor must be adequately protected.

SAFETY

- Do not remove the fan grilles
- Electrical connections must be made by skilled electricians in accordance with the attached electrical diagrams
- Exterior surfaces of heat exchangers may reach high

temperatures so adequate guards must be installed or the unit must be mounted in an inaccessible position

- Do not perform work on the hydraulic motor until the hydraulic pipelines have been disconnected

HOW TO CHOOSE RIGHT HEAT EXCHANGER

To choose right heat exchanger follows the below example:
Power to dissipate: 8 KW

Oil flow ISO VG 46: 50 lt/1'
Inlet oil temperature: 80°C
Ambient temperature: 40°C
Electric fan 12 Volt

You can calculate the specific coefficient of heat exchange (kW/°C) if you divide the power to dissipate with the difference between oil input temperature and ambient temperature:

$$8KW : 40 \text{ °C } (80\text{°C}-40\text{°C}) = 0,20 \text{ kW/°C}$$

Note the oil flow (50 lt/1') and specific exchange power (0,20 kW/°C) and research the cooler that has in performance diagram this result with direct electric fan.

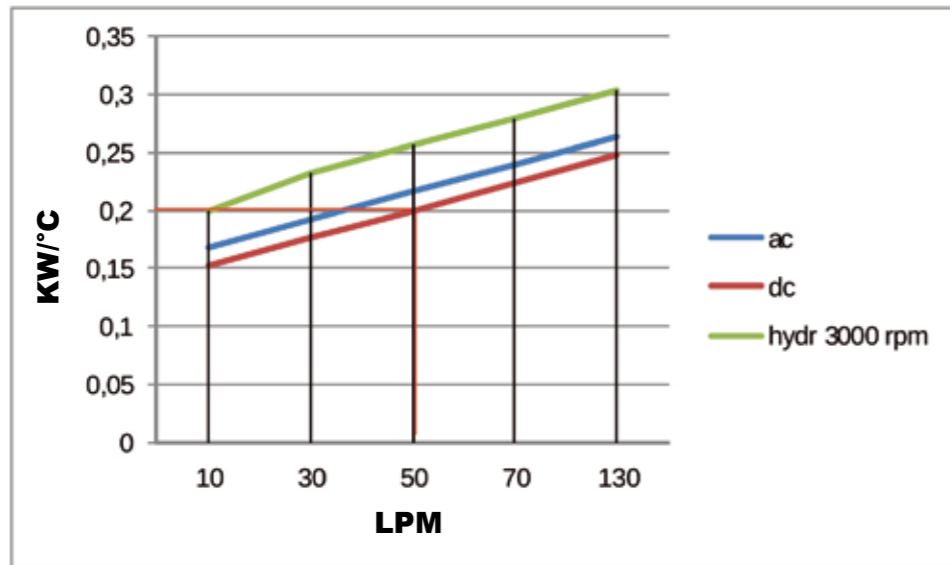

Lo scambiatore selezionato è il modello RO60/V4 - 12/24 V.
Per la corretta denominazione del prodotto consultare la scheda di CODIFICA PRODOTTO.
Se non sono conosciuti tutti i dati contattare IRA RADIATORI.

The selected heat exchanger is model RO60/V4 - 12/24 V.
For a complete description of heat exchanger consult the PRODUCT ORDERING CODE page.
If you don't know all required data for selecting cooler, please contact IRA RADIATORI.

CABLAGGIO 12/24 V - C.C.
12/24 V D.C. WIRING

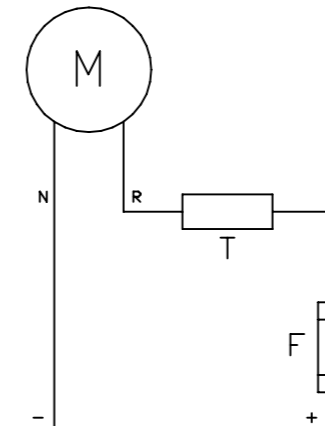

N - NERO / BLACK
R - ROSSO / RED
T - TERMOSTATO / THERMO SWITCH
F - FUSIBILE / FUSE

CABLAGGIO 230 V - C.A.
230 V A.C. WIRING

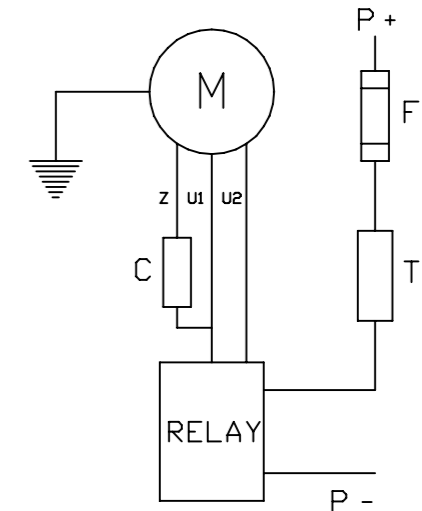

Z - MARRONE / BROWN
U1 - NERO / BLACK
U2 - VERDE / GREEN
T - TERMOSTATO / THERMO SWITCH
F - FUSIBILE / FUSE
P - ALIMENTAZIONE A RELE' / RELAY CURRENT SUPPLY
C - CONDENSATORE / VOLT CAPACITOR

Codifica prodotto serie RO
Ordering code RO series

R O 6 0 / V 4 V 1 2 A 4 0 X X

Serie Series	Modello Model	Ventilazione Fan	A/S	TERM.	ACC/MOD
-----------------	------------------	---------------------	-----	-------	---------

RO = RADIATORE OLIO ACCIAIO/RAME / OIL COOLER COPPER AND STEEL

V12 VCC
V24 VCC
V230 VAC
V400 VAC
V230/400 VAC B14
GR1
GR2

A = ASPIRANTE/SUCKING
S = SOFFIANTE/BLOWING

TERMOSTATI/THERMOSTAT
30 = 30/38°
40 = 40/48°
50 = 50/60°

ACCESSORI / MODIFICHE
COMPLEMENTS/MODIFICATIONS
P = PIEDI / FEET
A = MODIFICA SULLO STANDARD
A = CHANGE ON STANDARD VERSION

ESEMPIO:
RO60/V412V40
MODELLO RO60/V4 COMPLETO DI ELETTROVENTOLA 12 VOLT ASPIRANTE E TERMOSTATO FISSO T40/48°C.

EXAMPLE:
RO60/V412V40
MODEL RO60/V4 COMPLETE WITH ELECTRIC FAN 12V SUCHING, FIXED THERMOSTAT T40/48°C.

CABLAGGIO 230/400 V A STELLA
230/400V STAR WIRING

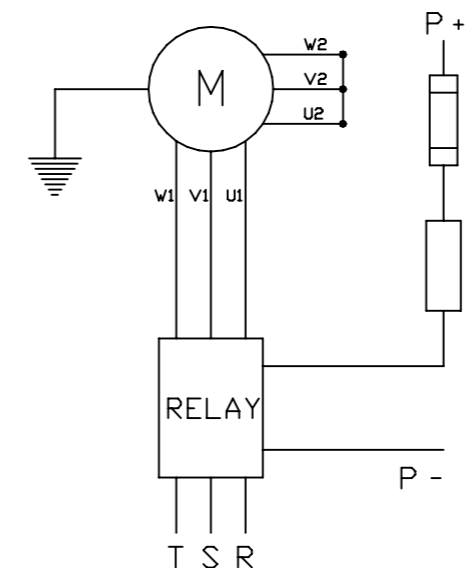

U1 - NERO / BLACK
U2 - VERDE / GREEN
V1 - AZZURRO / BLUE
V2 - BIANCO / WHITE
W1 - MARRONE / BROWN
W2 - GIALLO / YELLOW
T - TERMOSTATO / THERMO SWITCH
F - FUSIBILE / FUSE
P - ALIMENTAZIONE RELE' / RELAY CURRENT SUPPLY

CABLAGGIO 230/400 V A TRIANGOLO
230/400V TRIANGLE WIRING

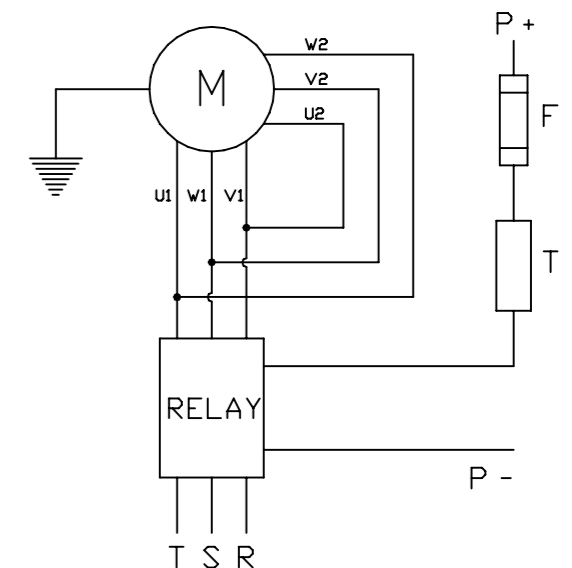

U1 - NERO / BLACK
U2 - VERDE / GREEN
V1 - AZZURRO / BLUE
V2 - BIANCO / WHITE
W1 - MARRONE / BROWN
W2 - GIALLO / YELLOW
T - TERMOSTATO / THERMO SWITCH
F - FUSIBILE / FUSE
P - ALIMENTAZIONE RELE' / RELAY CURRENT SUPPLY

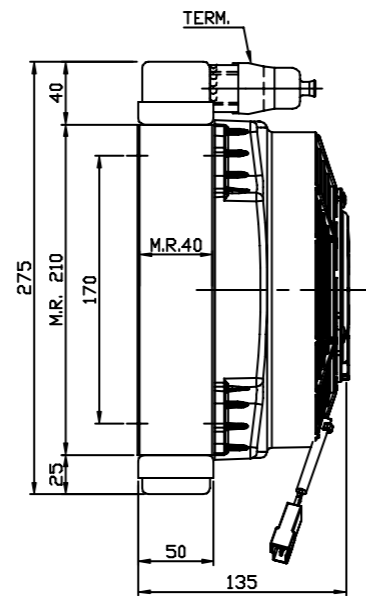
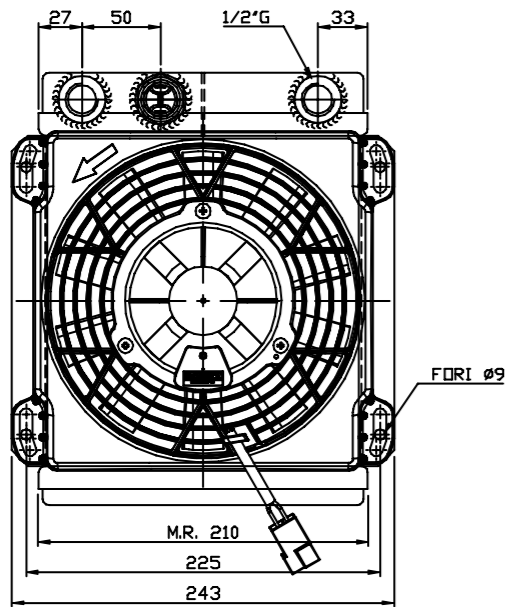

Vcc

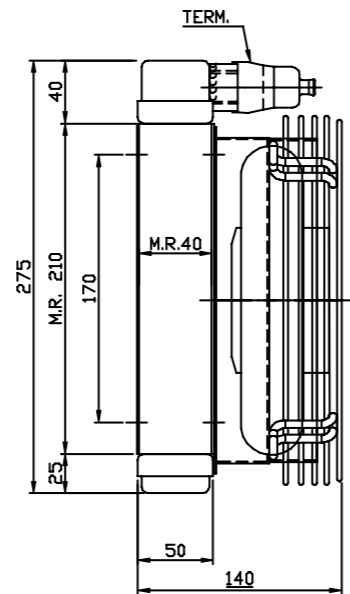
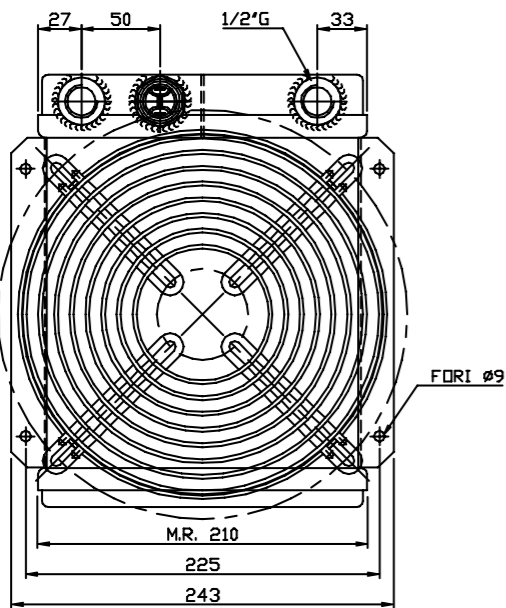

Vac

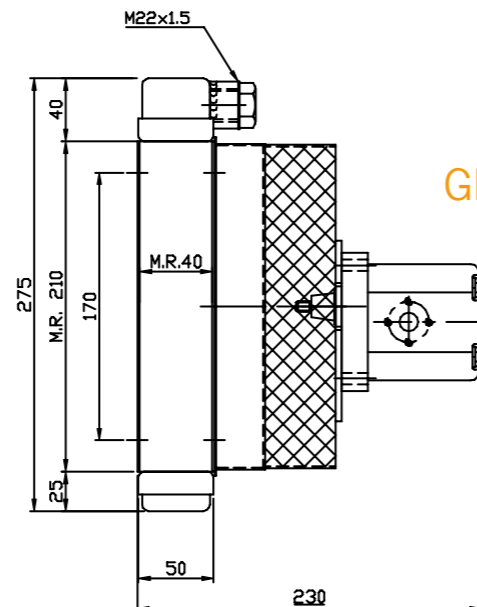
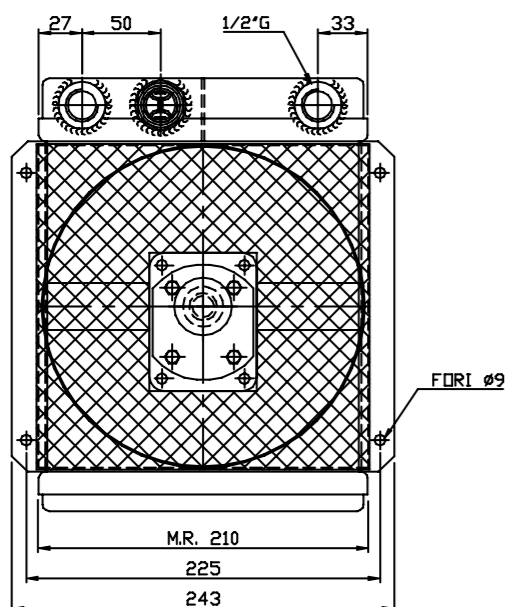

GR1

DATI TECNICI - TECHNICAL DATA

TENSIONE VOLTAGE	ASSORBIMENTO CURRENT	PORTATA ARIA AIR FLOW	PROTEZIONE PROTECTION	Ø
V	A	m ³ /h	IP	mm
12	6,2	630	68	190
24	3,1	630	68	190
230 Hz 50/60	0,30 / 0,34	890 / 990	44	200
230/400 Hz 50/60	0,29-0,17 / 0,23-0,13	890 / 990	44	200
Predisposizione GR1 - Prepared for GR1			/	190

DIAGRAMMA DI RENDIMENTO - PERFORMANCE DIAGRAM



DIAGRAMMA PERDITE DI CARICO - PRESSURE DROP DIAGRAM



Portata olio - Oil flow: 5-40 lt/1'

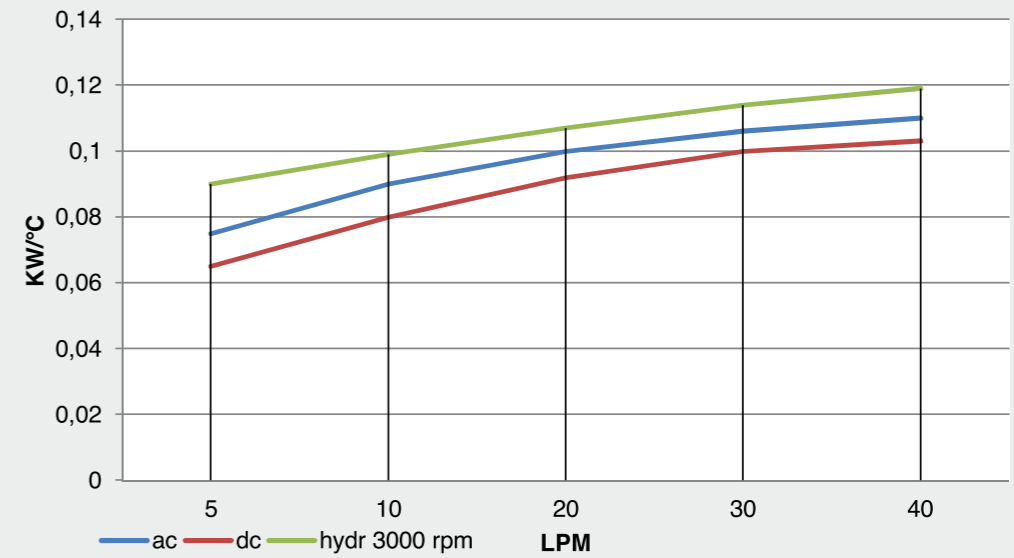
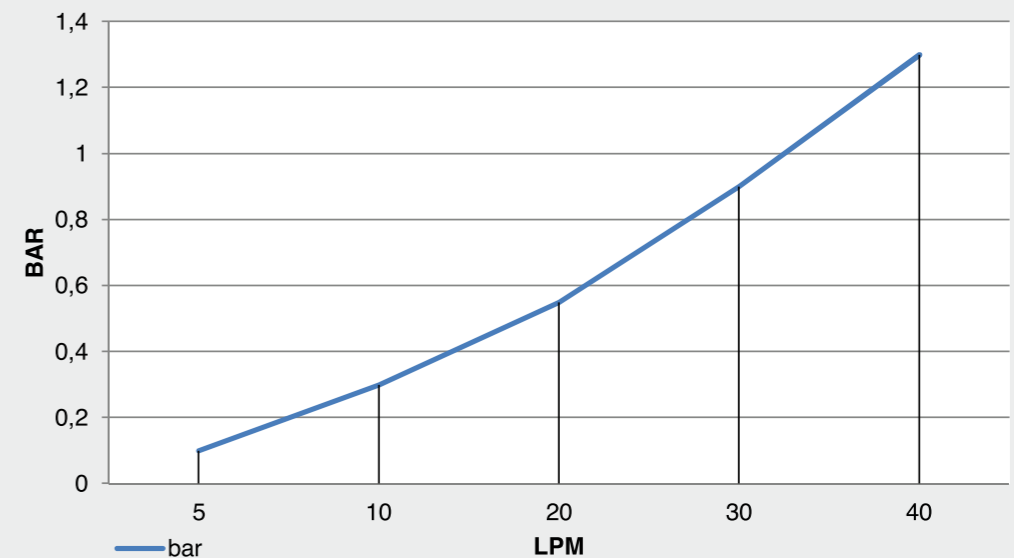
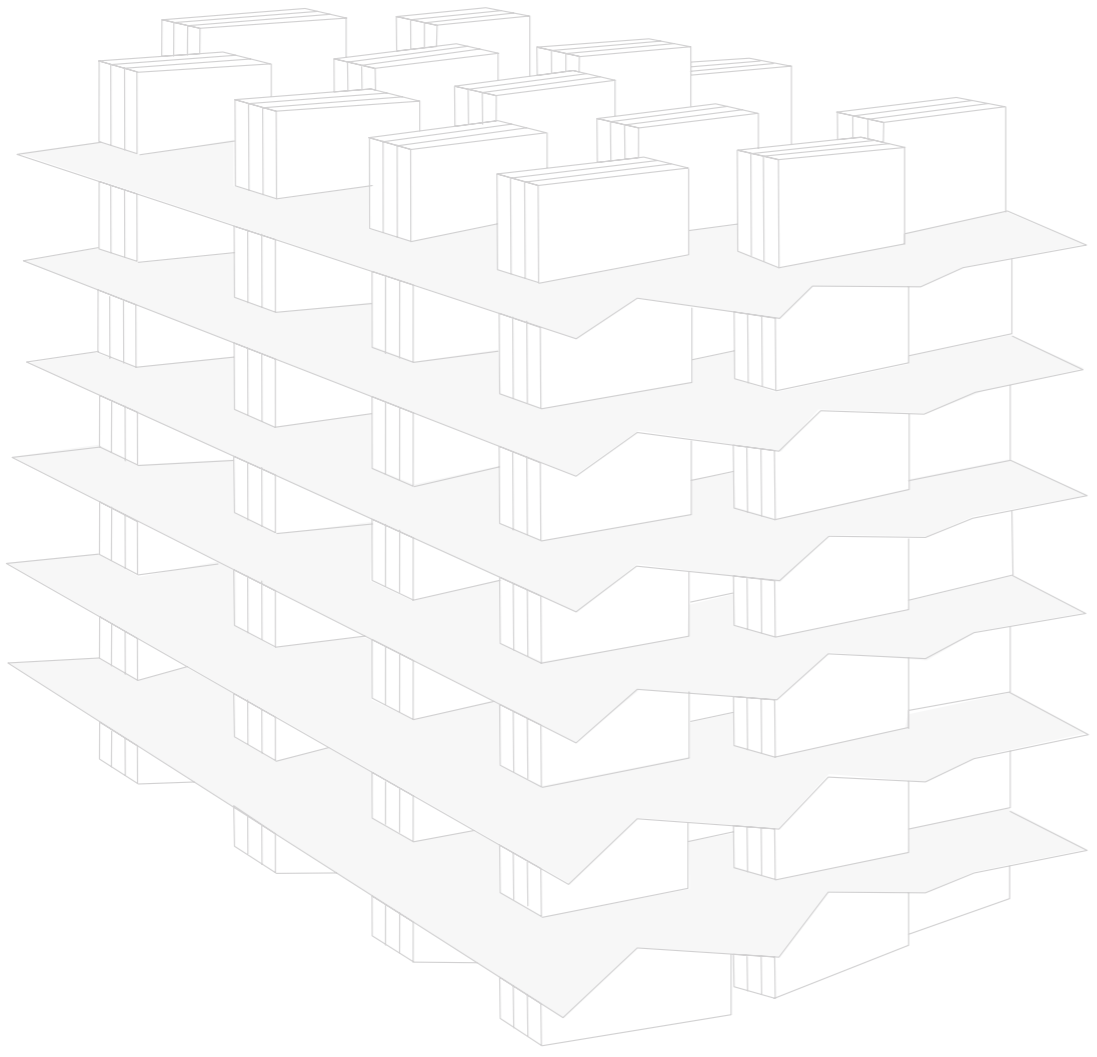
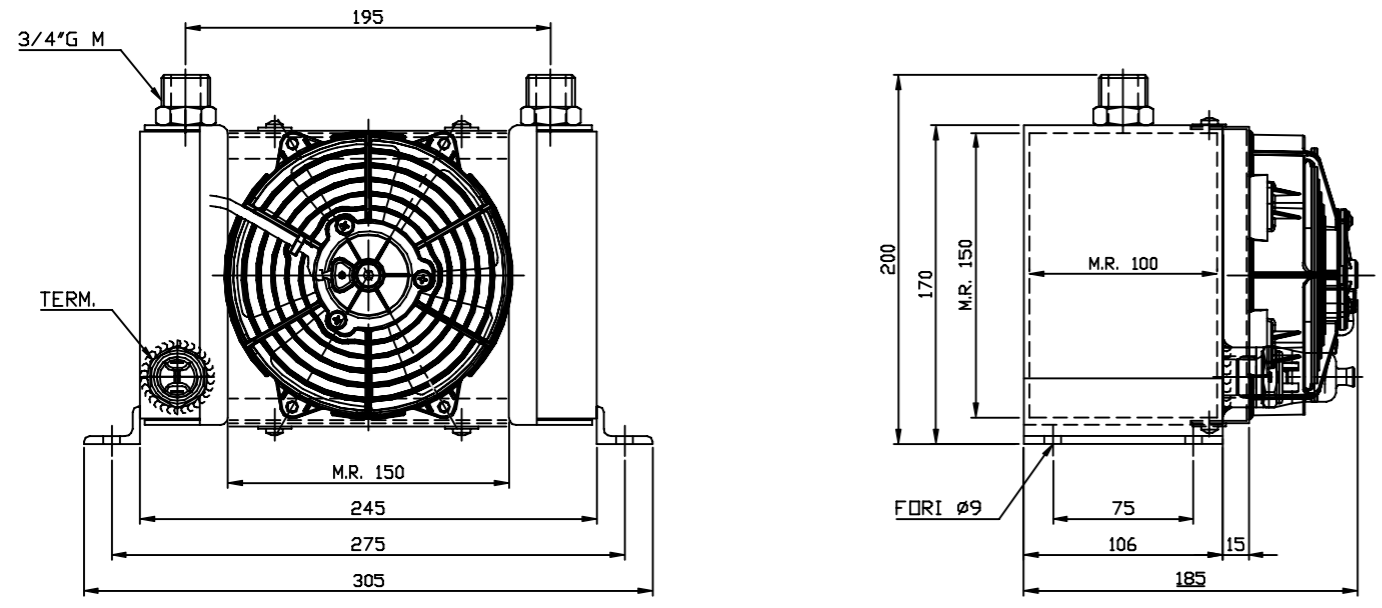

DATI TECNICI - TECHNICAL DATA

TENSIONE VOLTAGE	ASSORBIMENTO CURRENT	PORTATA ARIA AIR FLOW	PROTEZIONE PROTECTION	Ø
V	A	m ³ /h	IP	mm
12	2,65	360	66	130
24	2,65	360	66	130

DIAGRAMMA DI RENDIMENTO - PERFORMANCE DIAGRAM



DIAGRAMMA PERDITE DI CARICO - PRESSURE DROP DIAGRAM



Portata olio - Oil flow: 10-100 lt/1'

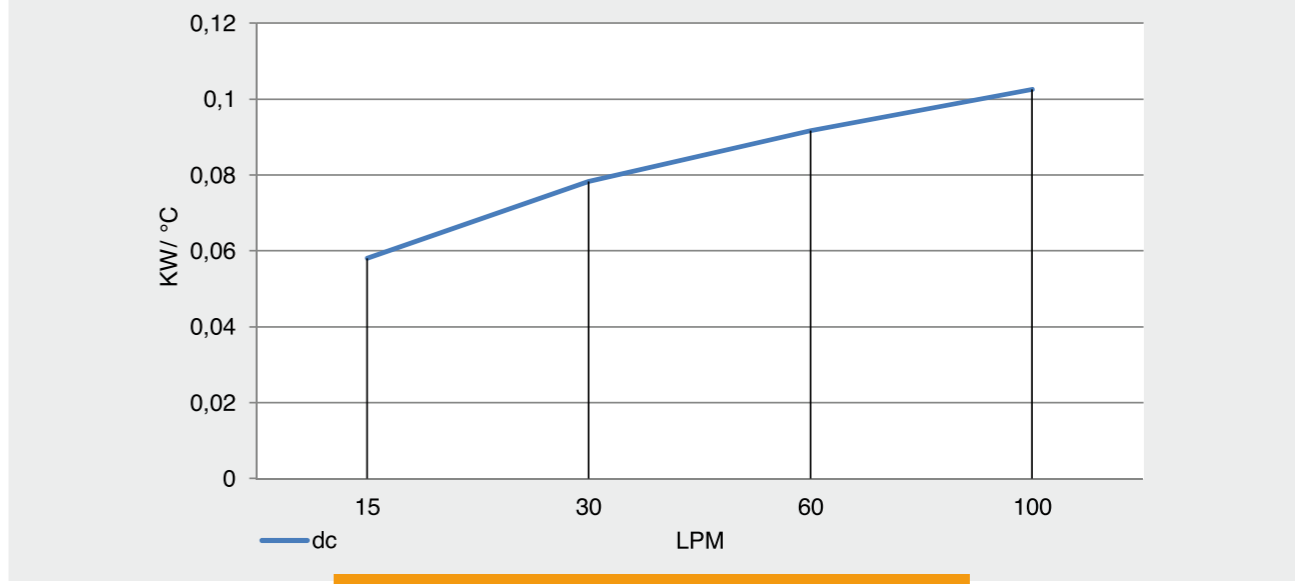
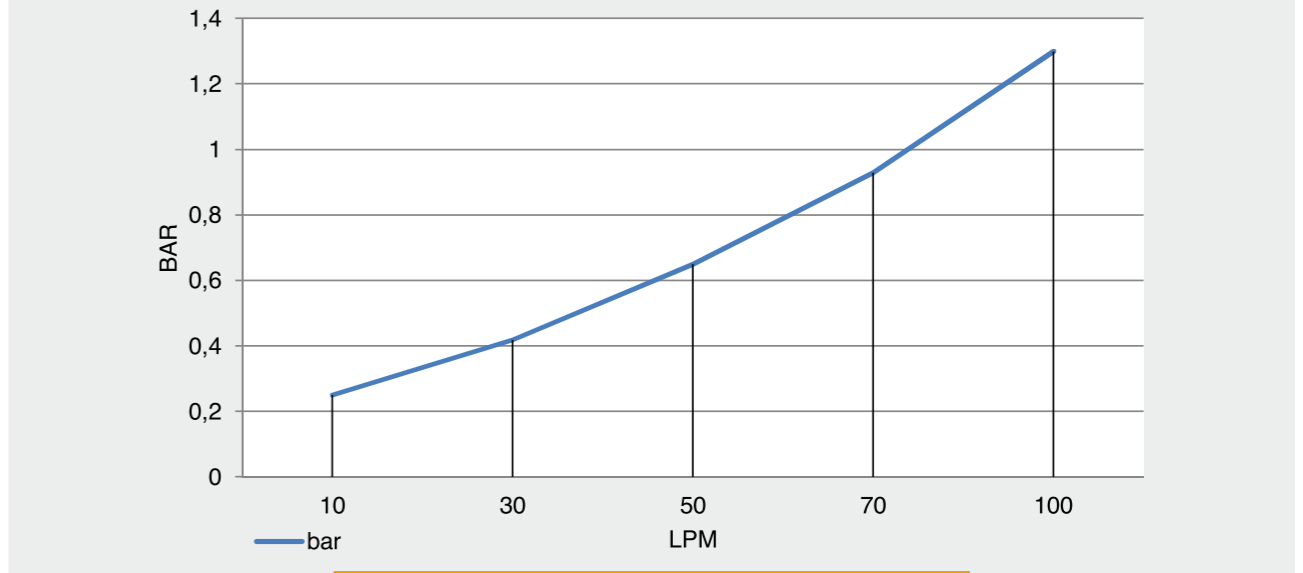
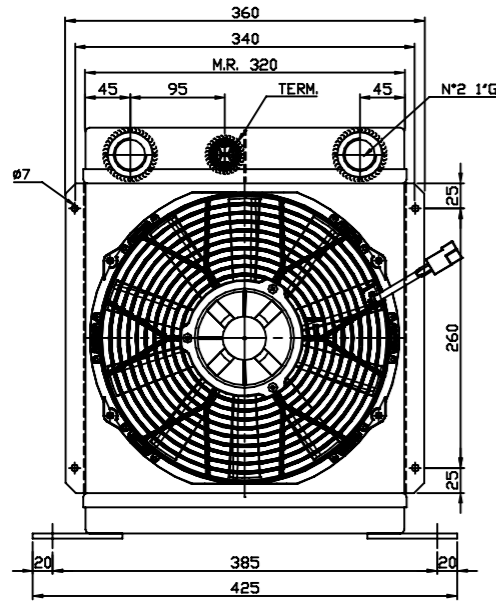

Vcc

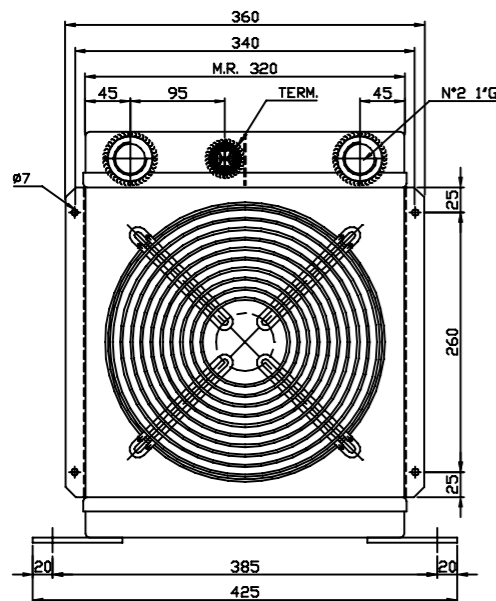
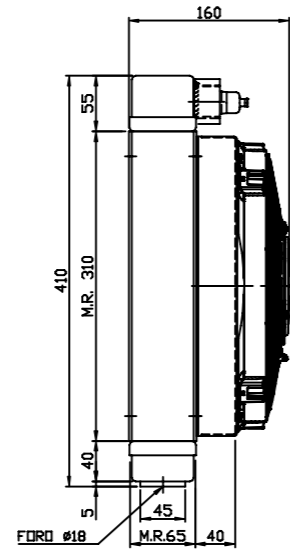

Vac

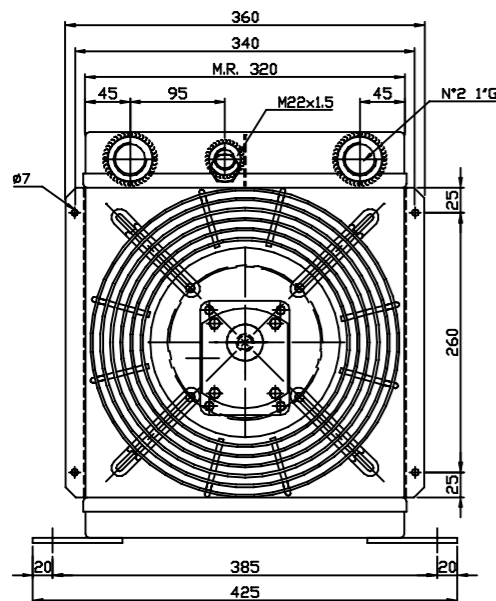
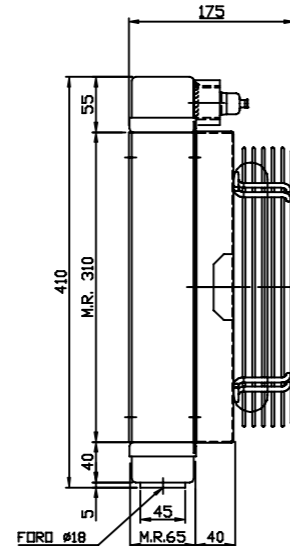

GR2

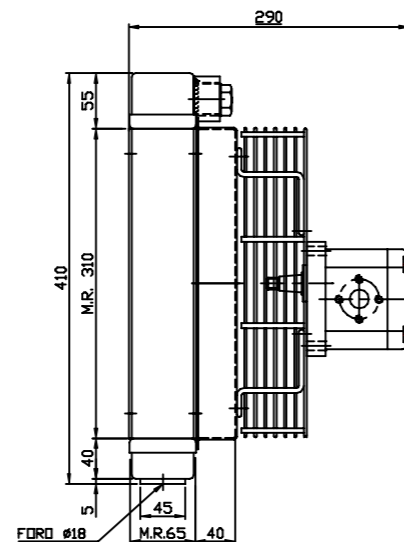

DATI TECNICI - TECHNICAL DATA

TENSIONE VOLTAGE	ASSORBIMENTO CURRENT	PORTATA ARIA AIR FLOW	PROTEZIONE PROTECTION	Ø
V	A	m ³ /h	IP	mm
12	8	1260	68	280
24	4	1240	68	280
230 Hz 50/60	0,51 / 0,66	1820 / 1970	44	250
230/400 Hz 50/60	0,34-0,20 / 0,40-0,23	1830 / 1950	44	250
Predisposizione GR2 - Prepared for GR2				280

DIAGRAMMA DI RENDIMENTO - PERFORMANCE DIAGRAM



DIAGRAMMA PERDITE DI CARICO - PRESSURE DROP DIAGRAM



Portata olio - Oil flow: 5-80 lt/1'

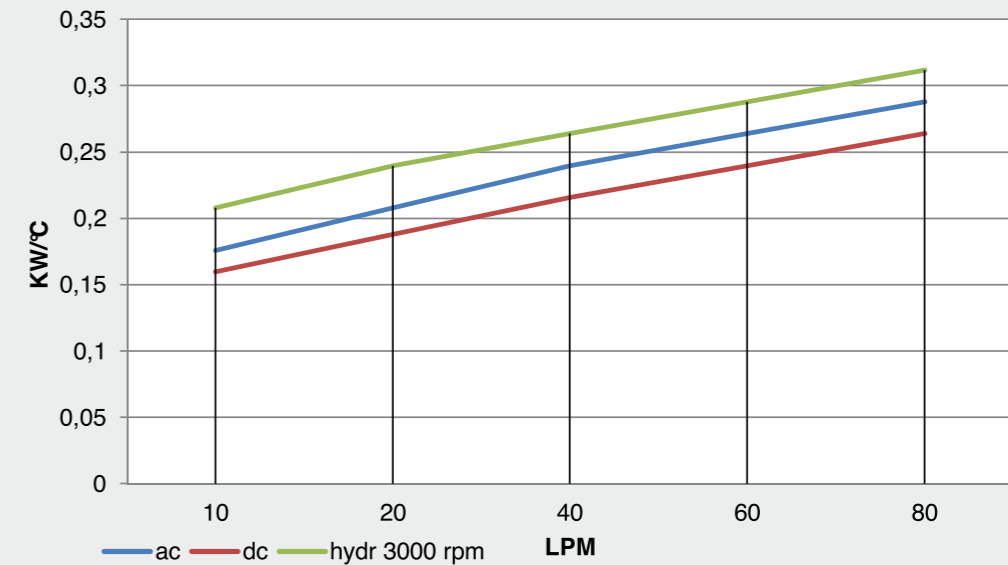
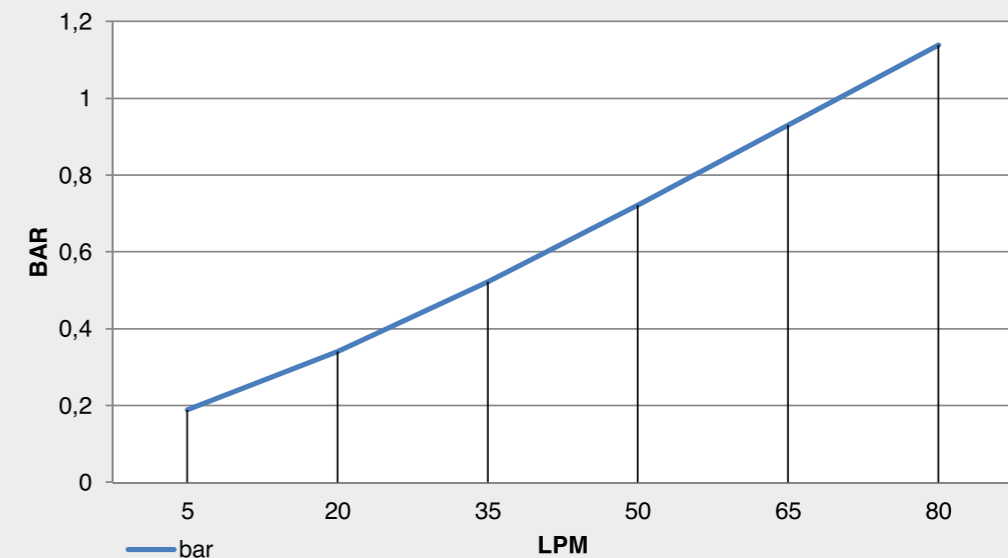
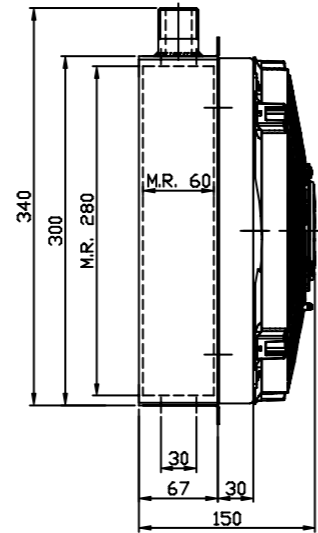
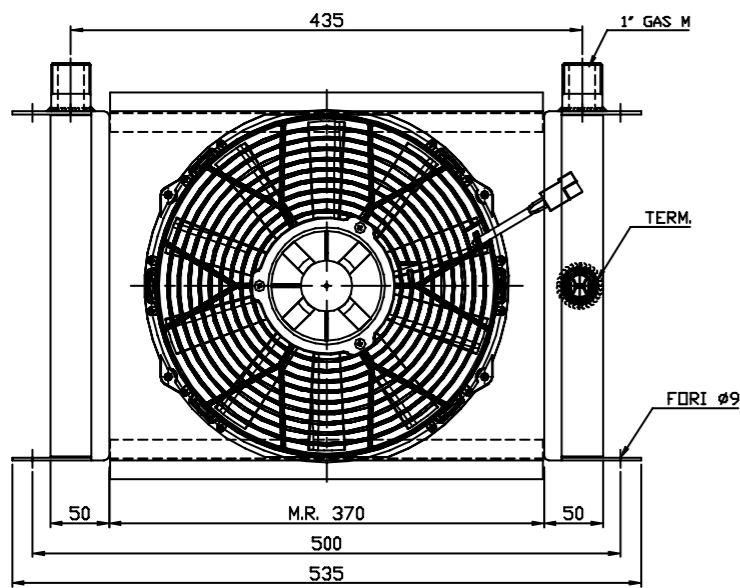

Vcc

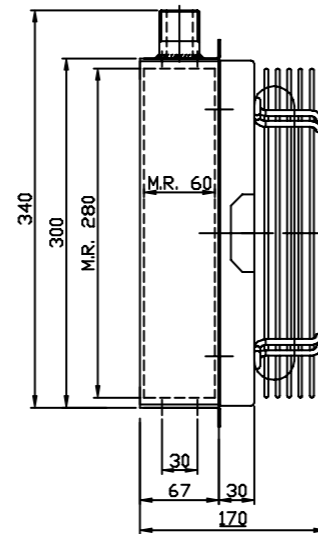
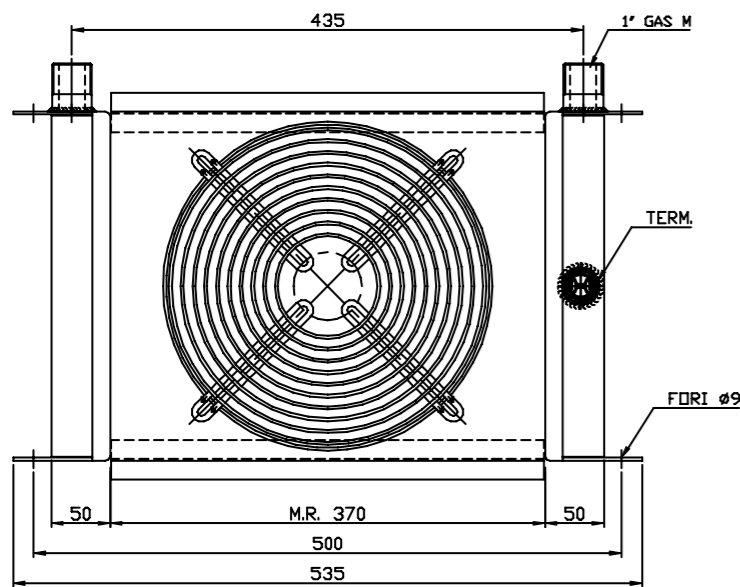

Vac

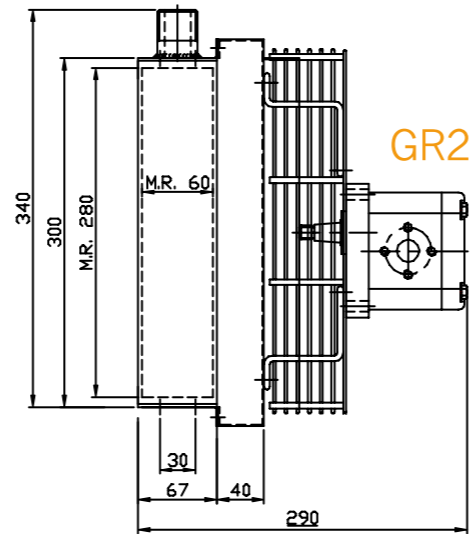
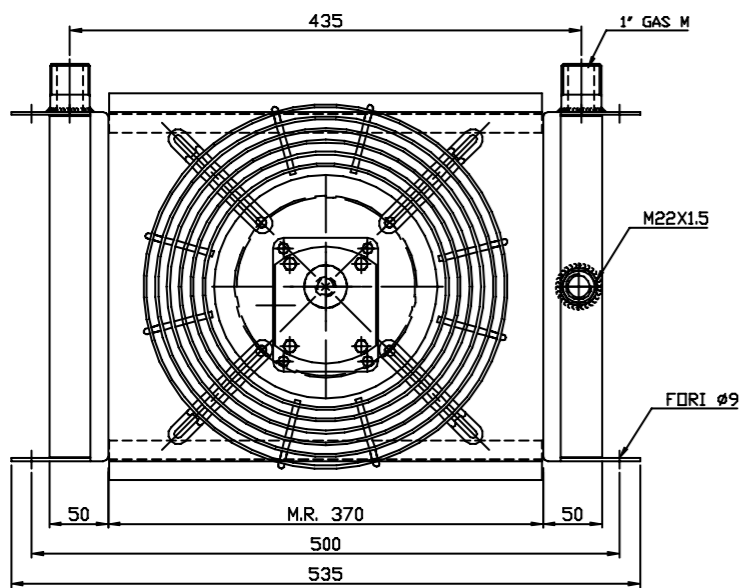

GR2

DATI TECNICI - TECHNICAL DATA

TENSIONE VOLTAGE	ASSORBIMENTO CURRENT	PORTATA ARIA AIR FLOW	PROTEZIONE PROTECTION	Ø
V	A	m ³ /h	IP	mm
12	8	1260	68	280
24	4	1240	68	280
230 Hz 50/60	0,51 / 0,66	1820 / 1970	44	250
230/400 Hz 50/60	0,34-0,20 / 0,40-0,23	1830 / 1950	44	250
Predisposizione GR2 - Prepared for GR2				280

DIAGRAMMA DI RENDIMENTO - PERFORMANCE DIAGRAM



DIAGRAMMA PERDITE DI CARICO - PRESSURE DROP DIAGRAM



Portata olio - Oil flow: 10-140 lt/1'

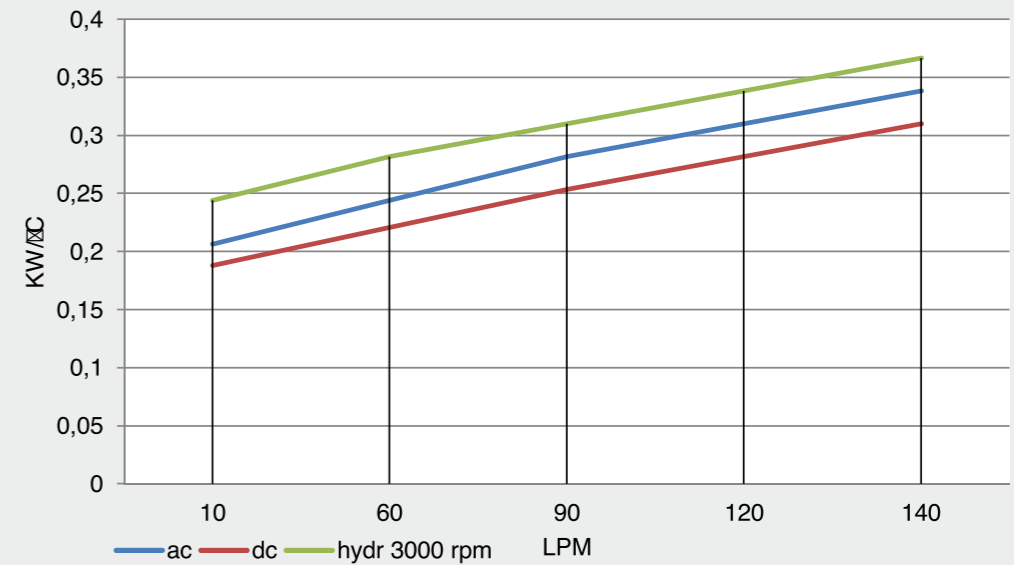
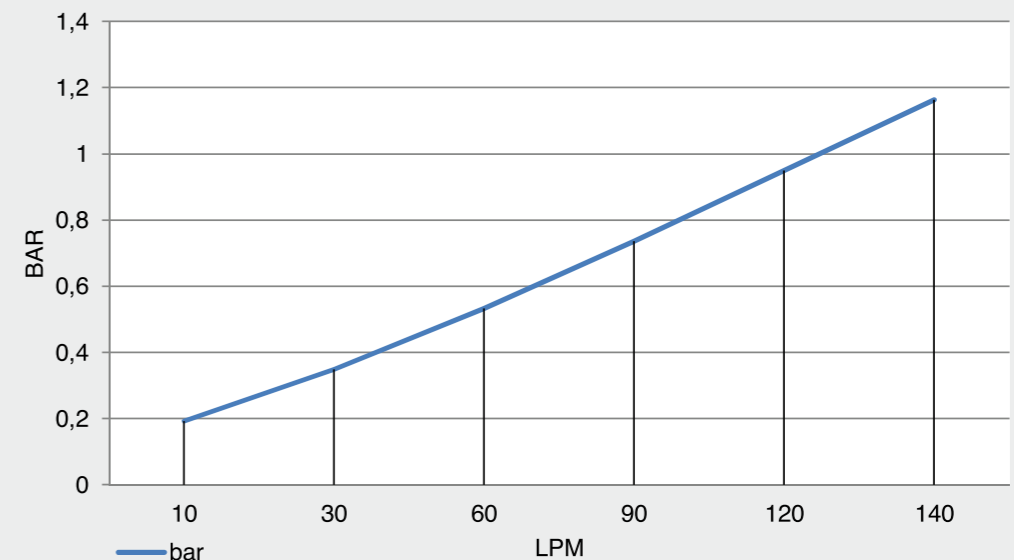
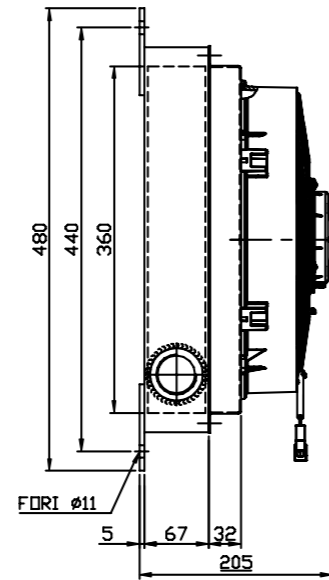
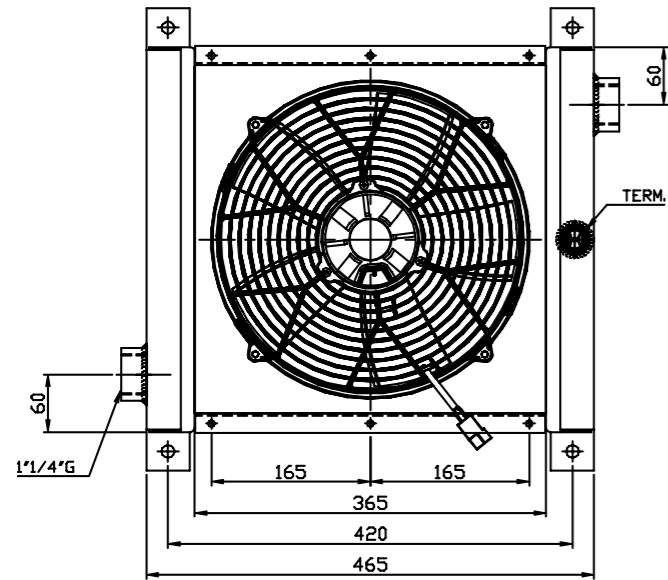

Vcc

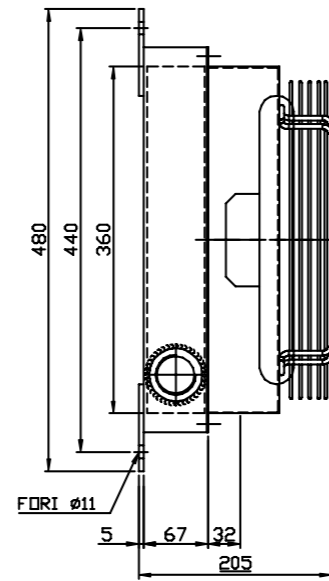
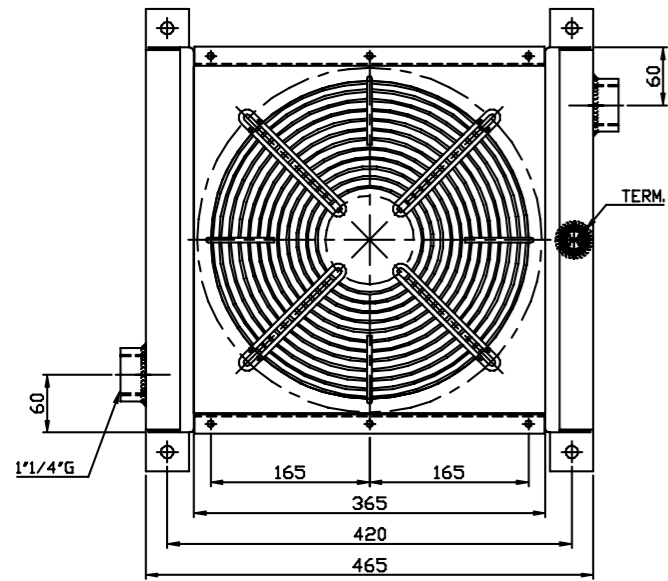

Vac

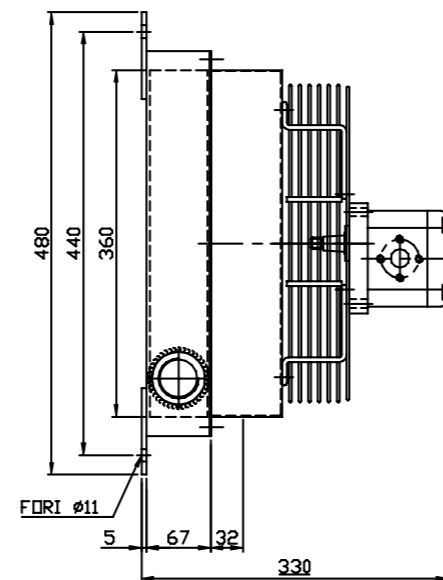
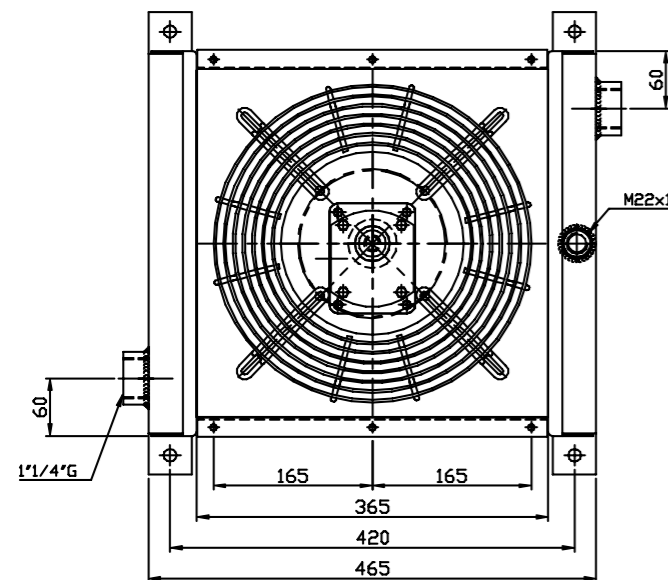

GR2

DATI TECNICI - TECHNICAL DATA

TENSIONE VOLTAGE	ASSORBIMENTO CURRENT	PORTATA ARIA AIR FLOW	PROTEZIONE PROTECTION	Ø
V	A	m ³ /h	IP	mm
12	11,4	1800	68	2305
24	5,5	1780	68	305
230 Hz 50/60	1,1 / 1,55	3410 / 3740	44	300
230/400 Hz 50/60	0,62-0,36 / 0,83-0,48	3130 / 3350	44	300
Predisposizione GR2 - Prepared for GR2			/	300

DIAGRAMMA DI RENDIMENTO - PERFORMANCE DIAGRAM



DIAGRAMMA PERDITE DI CARICO - PRESSURE DROP DIAGRAM



Portata olio - Oil flow: 25-170 lt/1'

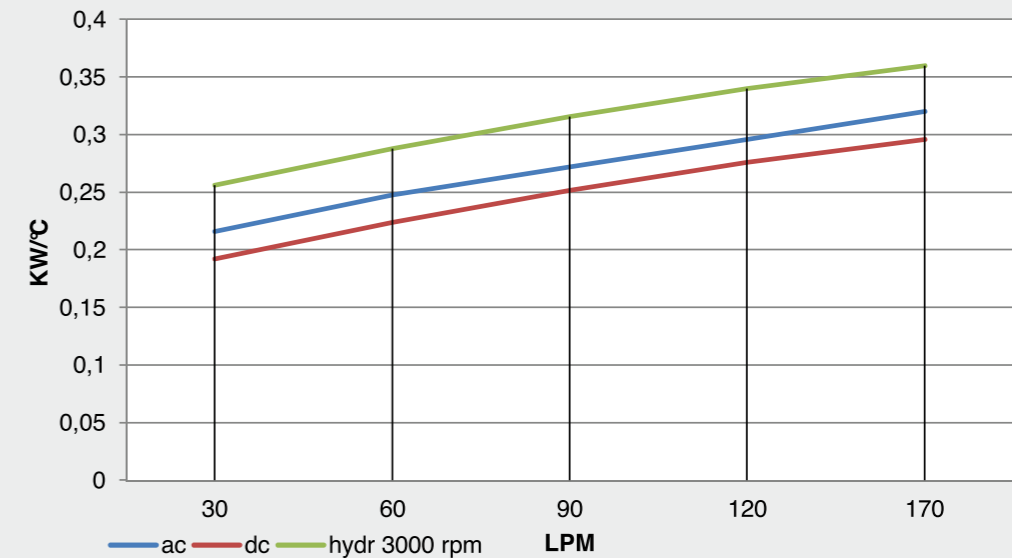
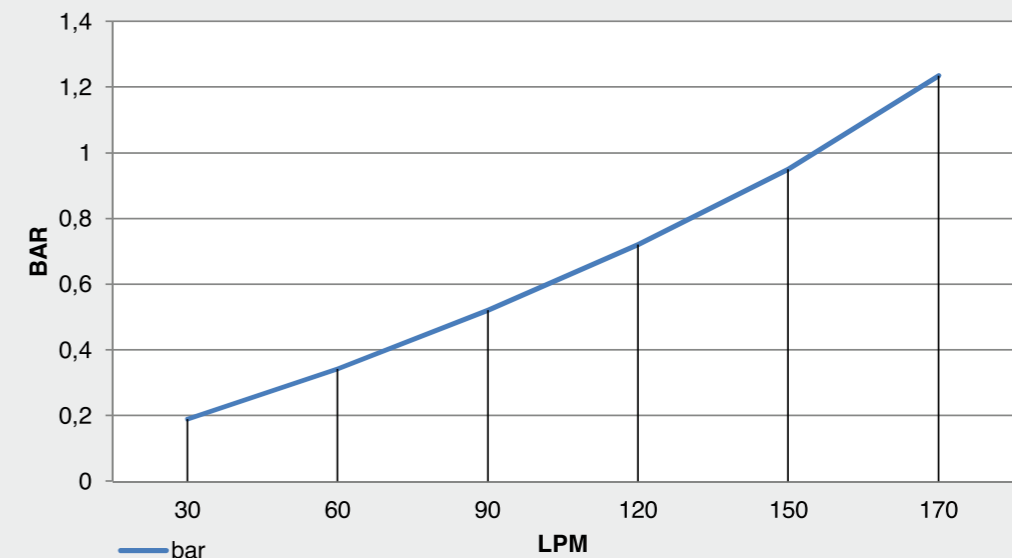
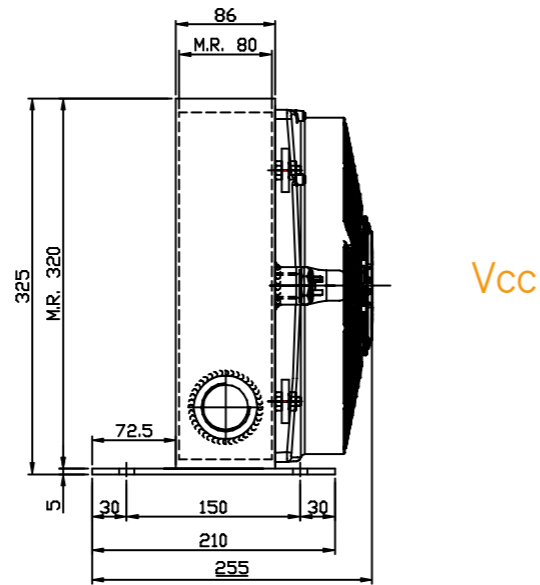
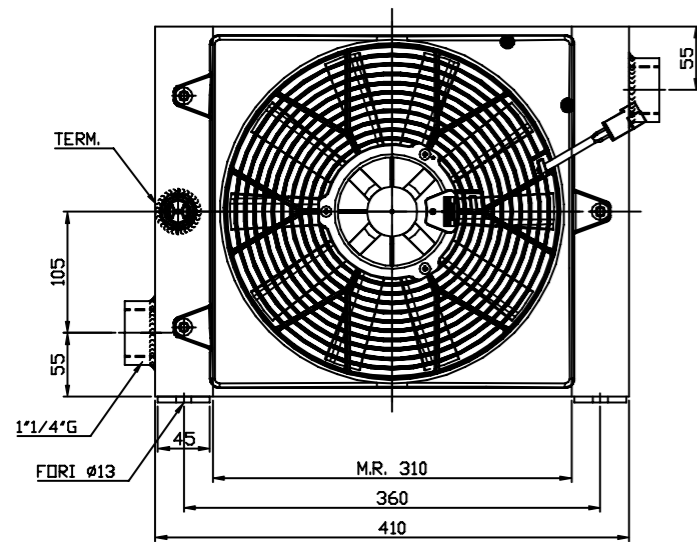

Vcc

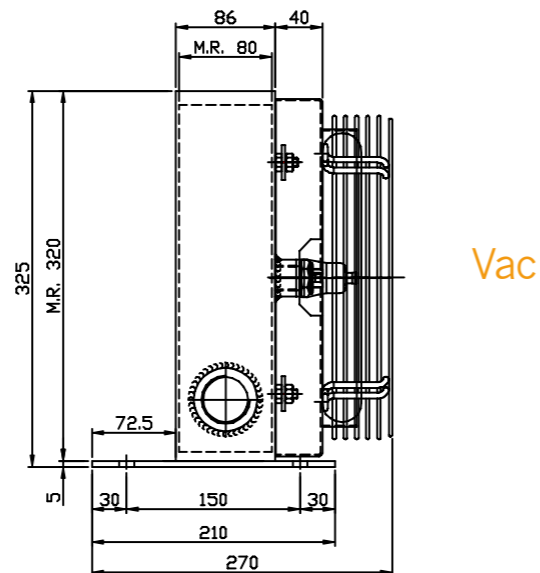
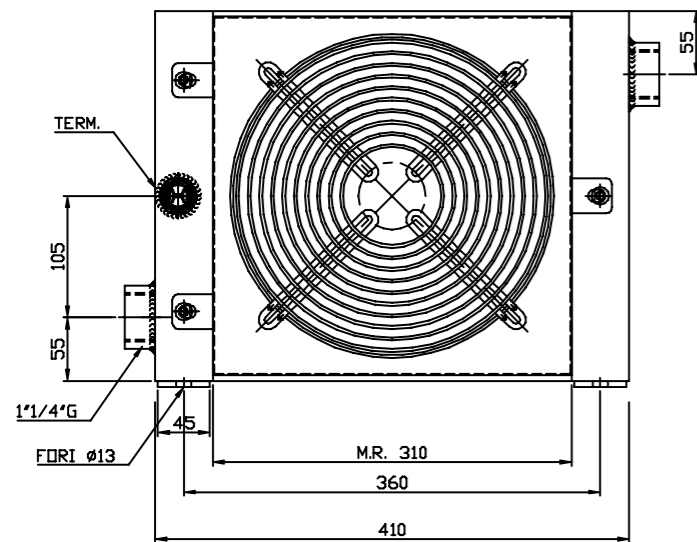

Vac

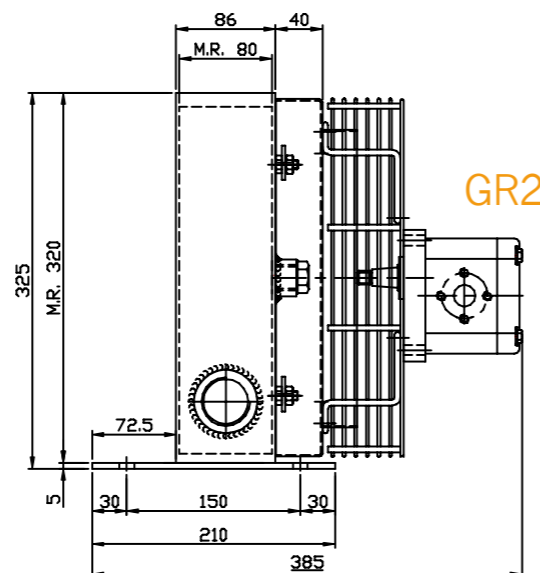
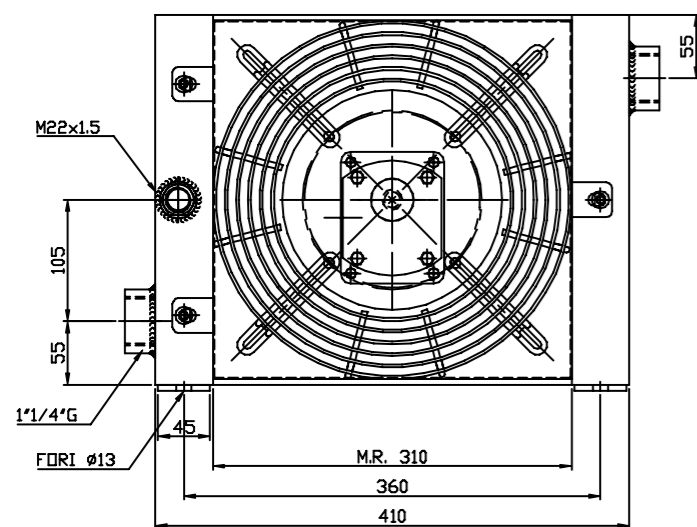

GR2

DATI TECNICI - TECHNICAL DATA

TENSIONE VOLTAGE	ASSORBIMENTO CURRENT	PORTATA ARIA AIR FLOW	PROTEZIONE PROTECTION	Ø
V	A	m ³ /h	IP	mm
12	7,3	1450	68	280
24	3,7	1470	68	280
230 Hz 50/60	0,51 / 0,66	1820 / 1970	44	250
230/400 Hz 50/60	0,34-0,20 / 0,40-0,23	1830 / 1950	44	250
Predisposizione GR2 - Prepared for GR2				280

DIAGRAMMA DI RENDIMENTO - PERFORMANCE DIAGRAM



DIAGRAMMA PERDITE DI CARICO - PRESSURE DROP DIAGRAM



Portata olio - Oil flow: 30-180 lt/1'

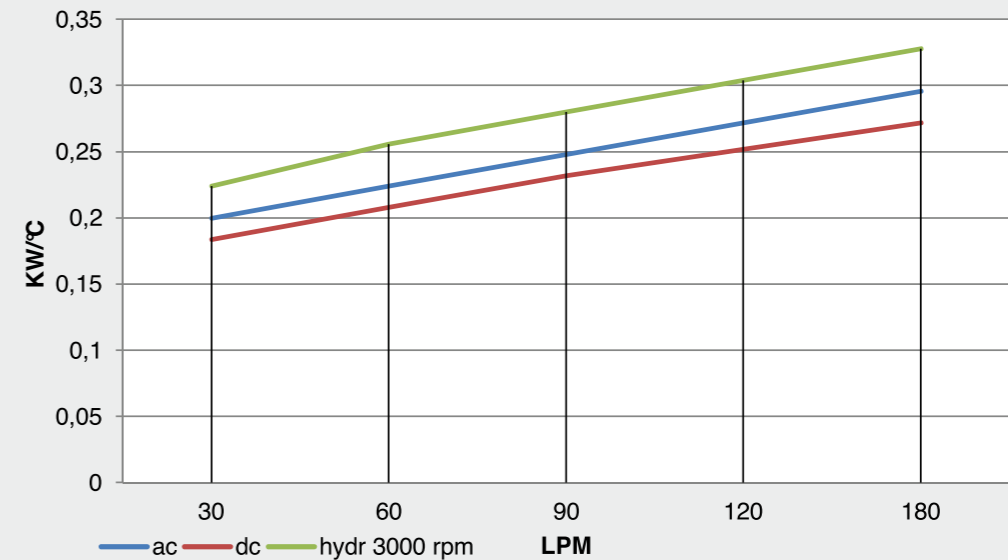
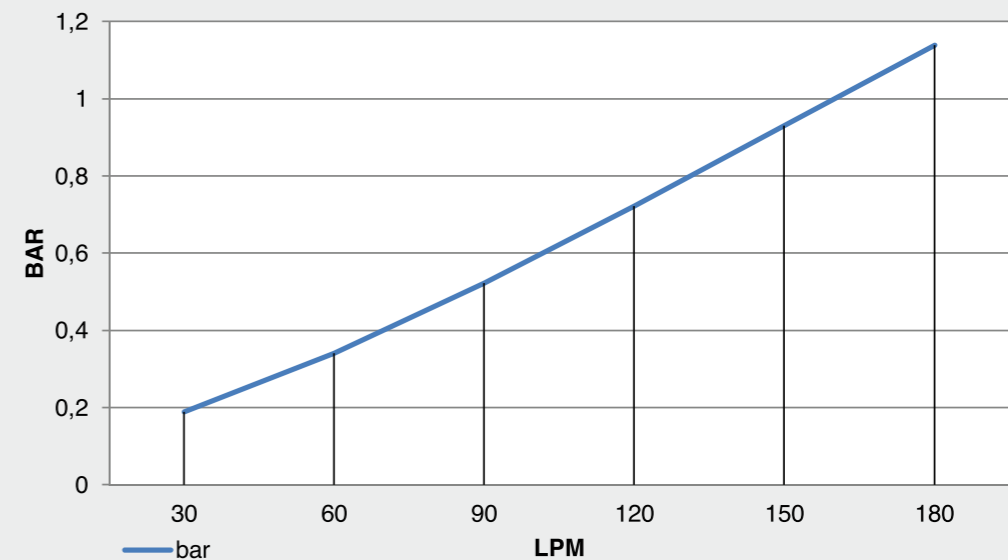
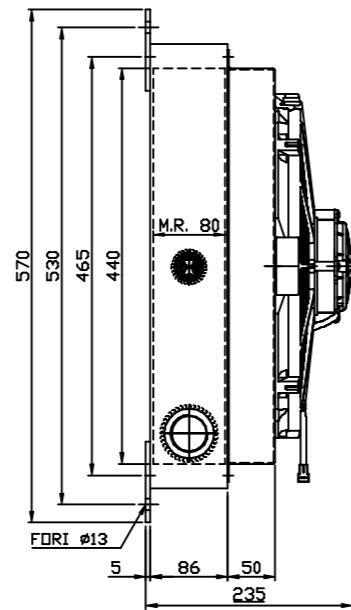
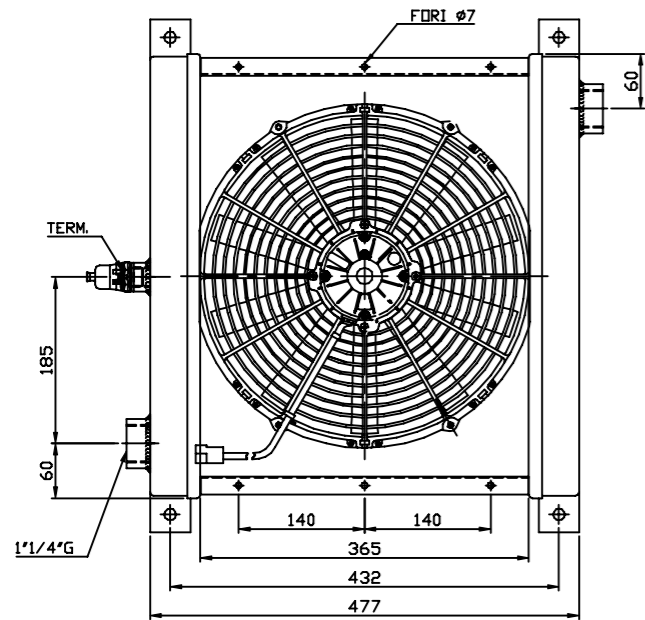

Vcc

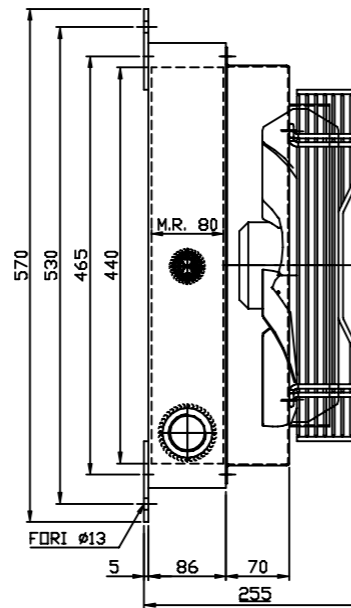
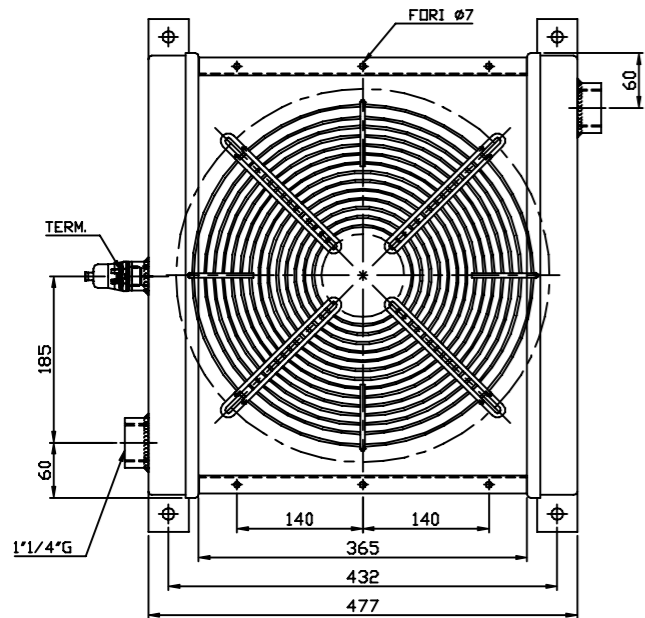

Vac

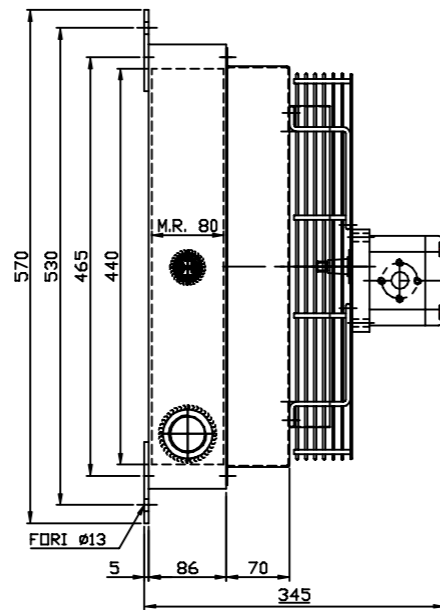
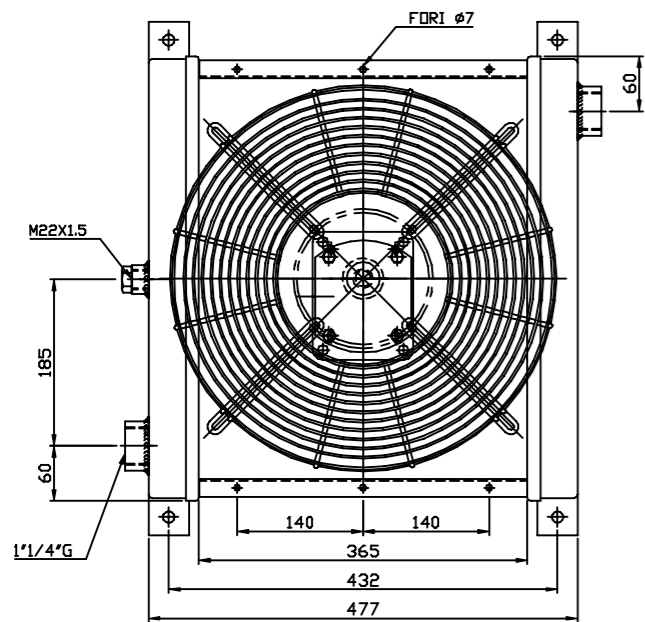

GR2

DATI TECNICI - TECHNICAL DATA

TENSIONE VOLTAGE	ASSORBIMENTO CURRENT	PORTATA ARIA AIR FLOW	PROTEZIONE PROTECTION	Ø
V	A	m ³ /h	IP	mm
12	18,7	2840	68	350
24	10,1	2810	68	350
230 Hz 50/60	0,58 / 0,80	3250 / 3640	44	350
230/400 Hz 50/60	0,73-0,42 / 0,64-0,37	3340 / 3815	44	350
Predisposizione GR2 - Prepared for GR2			/	300

DIAGRAMMA DI RENDIMENTO - PERFORMANCE DIAGRAM



DIAGRAMMA PERDITE DI CARICO - PRESSURE DROP DIAGRAM



Portata olio - Oil flow: 40-265 lt/1'

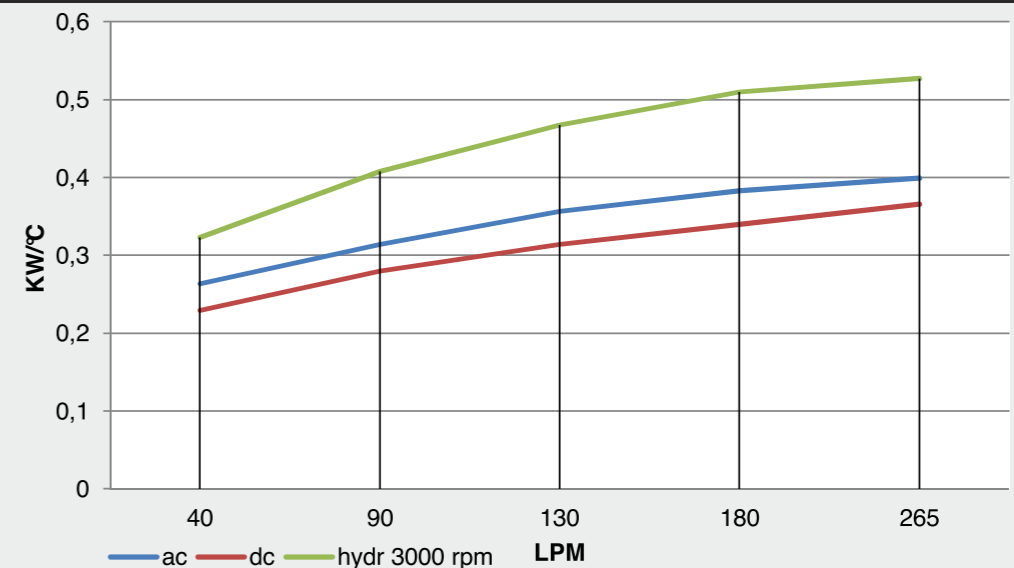
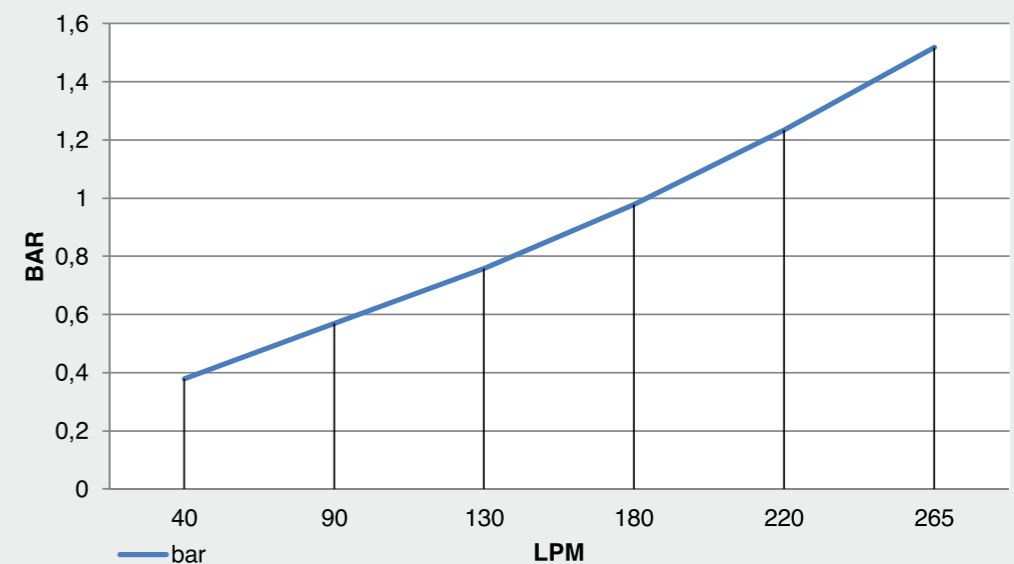
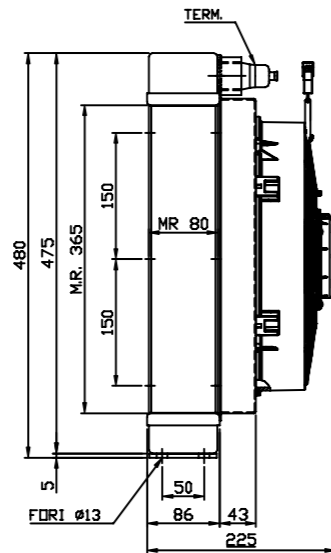
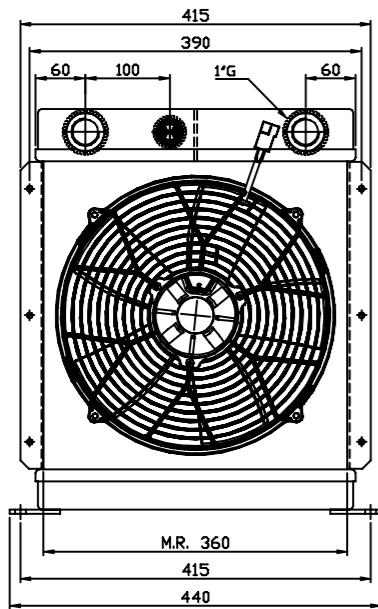

Vcc

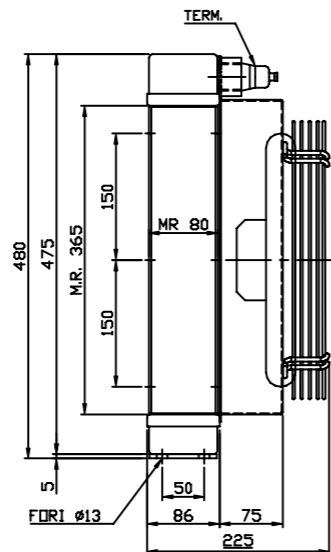
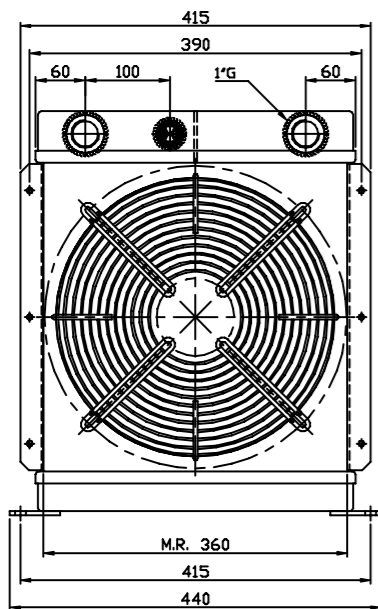

Vac

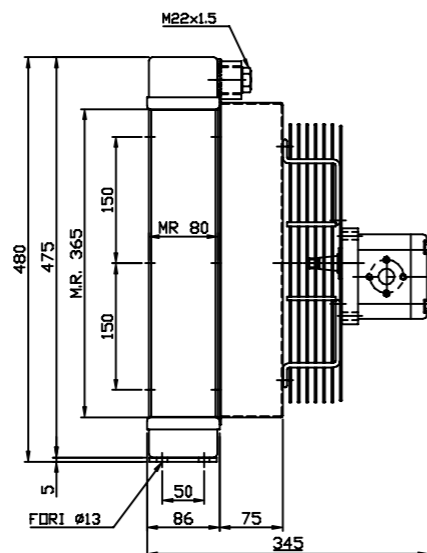
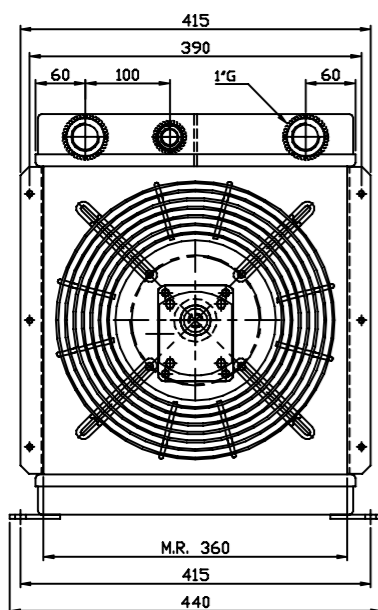

GR2

DATI TECNICI - TECHNICAL DATA

TENSIONE VOLTAGE	ASSORBIMENTO CURRENT	PORTATA ARIA AIR FLOW	PROTEZIONE PROTECTION	Ø
V	A	m ³ /h	IP	mm
12	20,7	2490	68	305
24	10	2520	68	305
230 Hz 50/60	1,1 / 1,55	3410 / 3740	44	300
230/400 Hz 50/60	0,62-0,36 / 0,83-0,48	3130 / 3350	44	300
Predisposizione GR2 - Prepared for GR2			/	300

DIAGRAMMA DI RENDIMENTO - PERFORMANCE DIAGRAM



DIAGRAMMA PERDITE DI CARICO - PRESSURE DROP DIAGRAM



Portata olio - Oil flow: 10-100 lt/1'

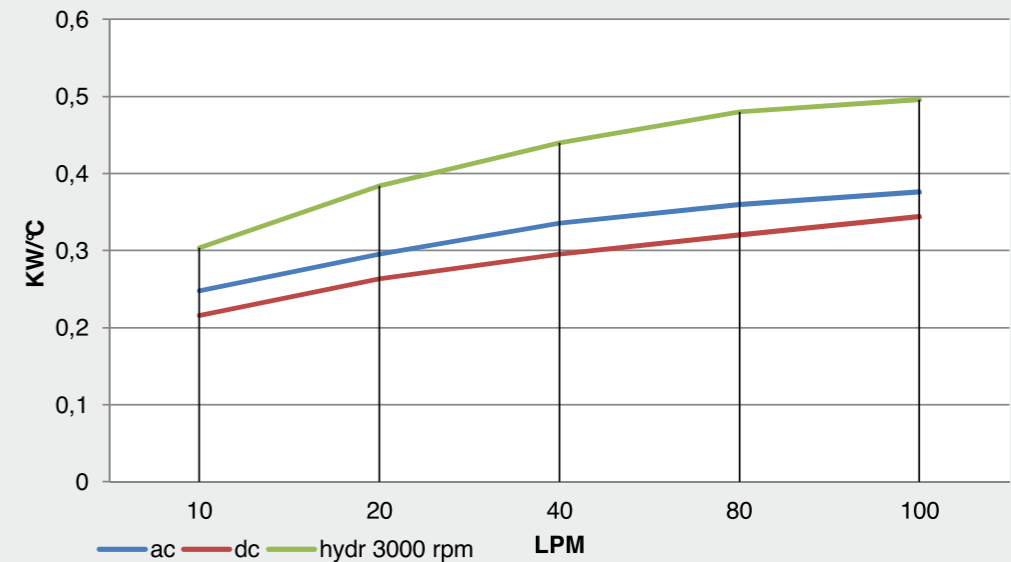
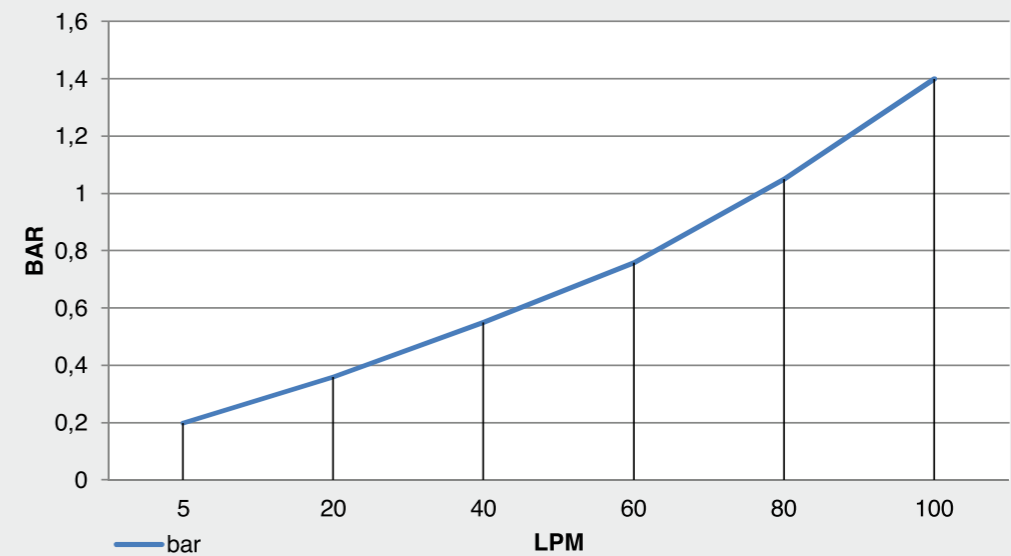
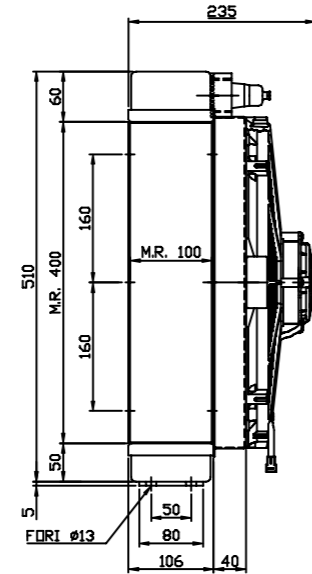
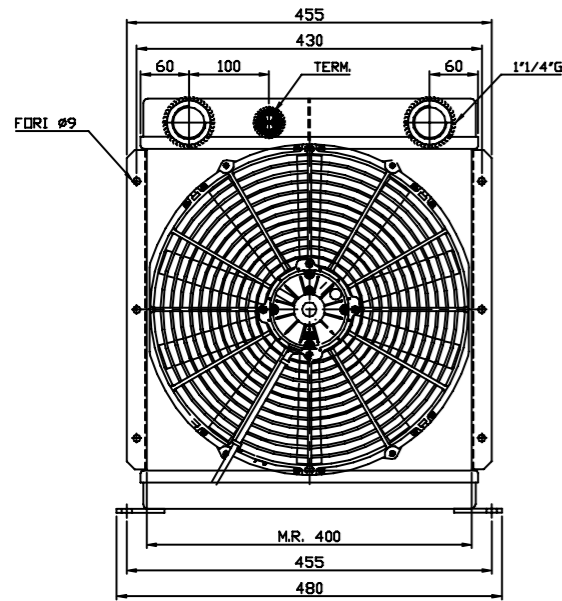

Vcc

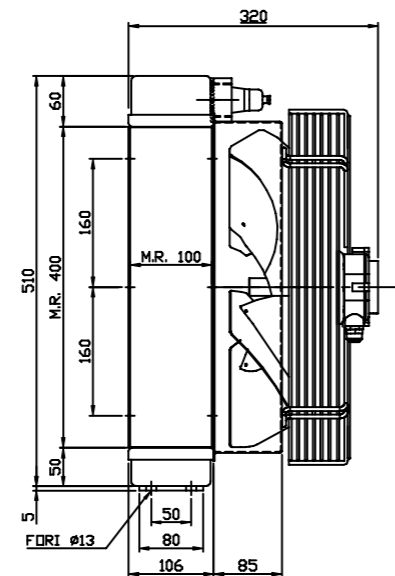
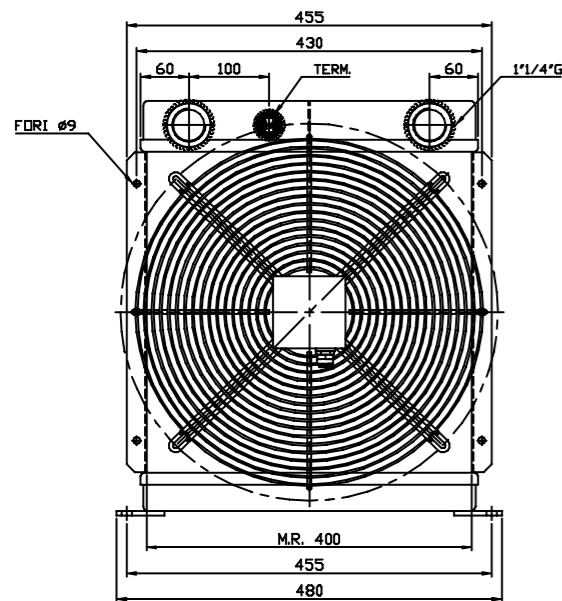

Vac

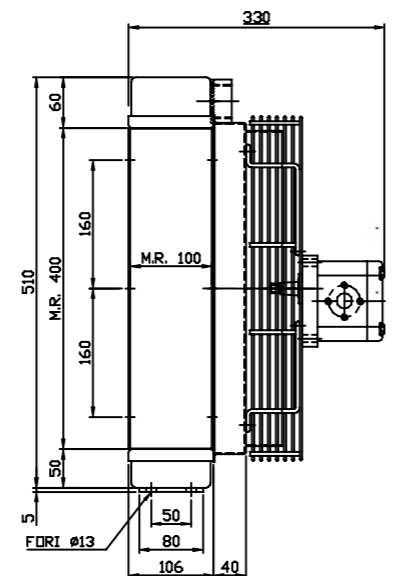
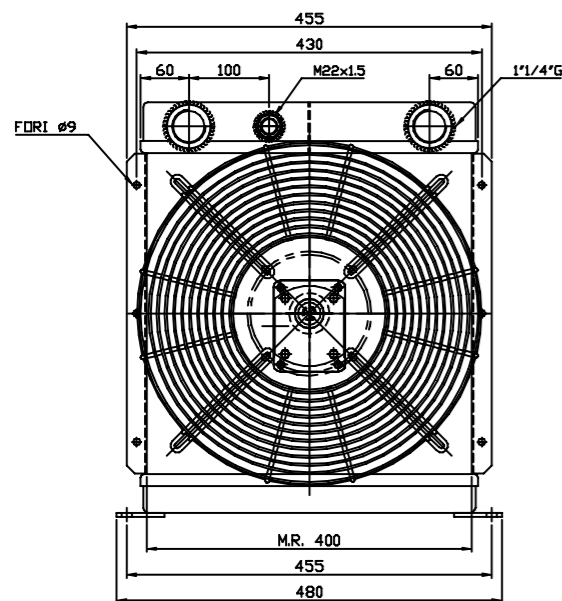

GR2

DATI TECNICI - TECHNICAL DATA

TENSIONE VOLTAGE	ASSORBIMENTO CURRENT	PORTATA ARIA AIR FLOW	PROTEZIONE PROTECTION	Ø
V	A	m ³ /h	IP	mm
12	18,1	3220	68	385
24	8	3080	68	385
230 Hz 50/60	0,73 / 1,06	4235 / 4950	44	400
230/400 Hz 50/60	0,76-0,44 / 0,68-0,39	4000 / 4610	44	400
Predisposizione GR2 - Prepared for GR2			/	380

DIAGRAMMA DI RENDIMENTO - PERFORMANCE DIAGRAM



DIAGRAMMA PERDITE DI CARICO - PRESSURE DROP DIAGRAM



Portata olio - Oil flow: 10-150 lt/1'

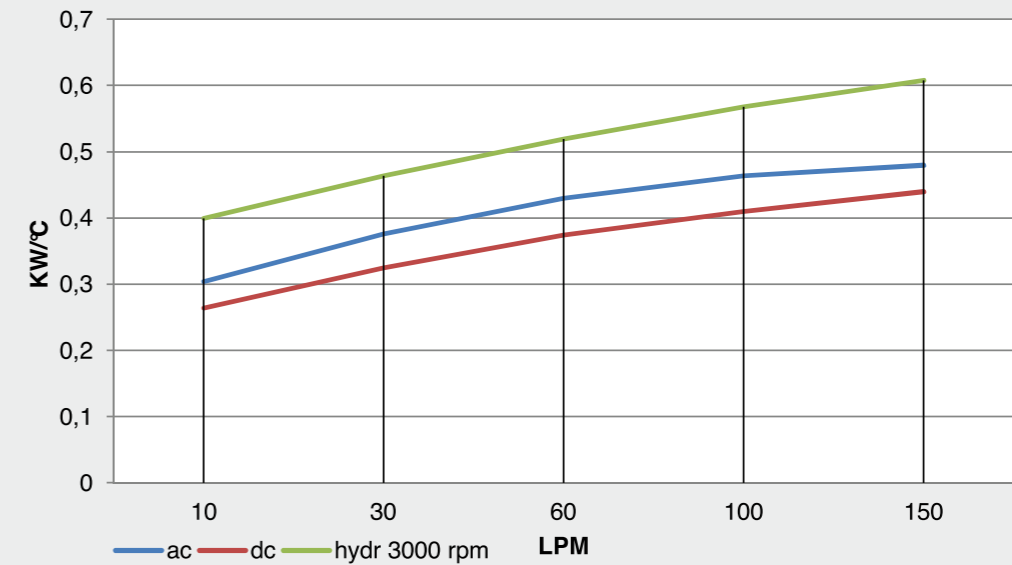
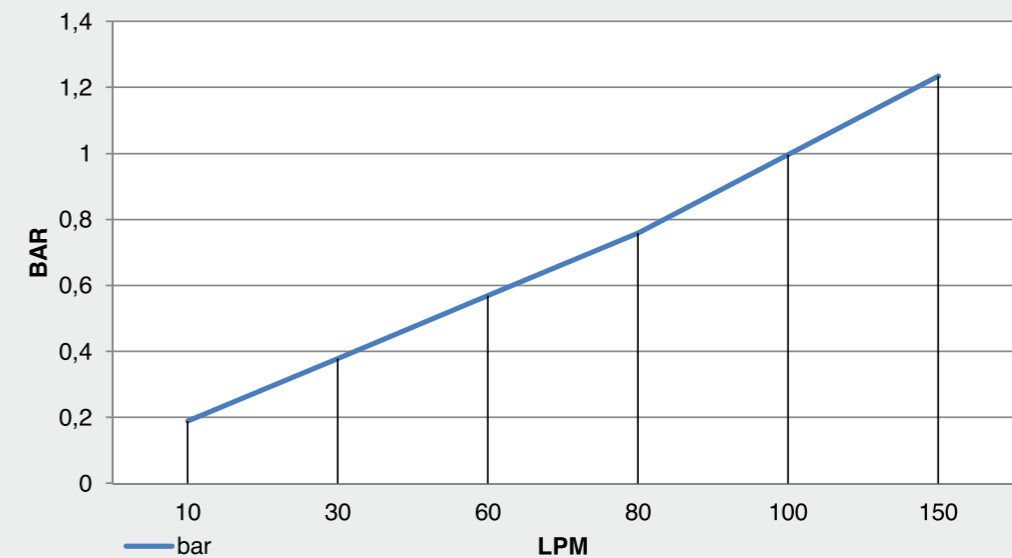
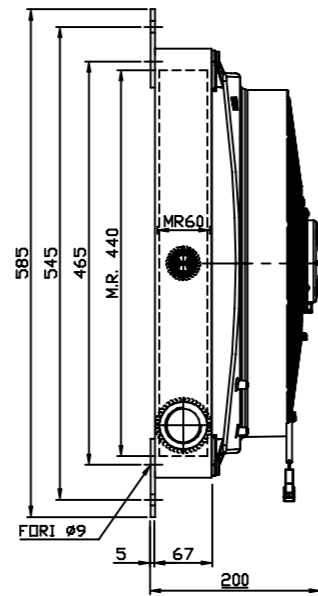
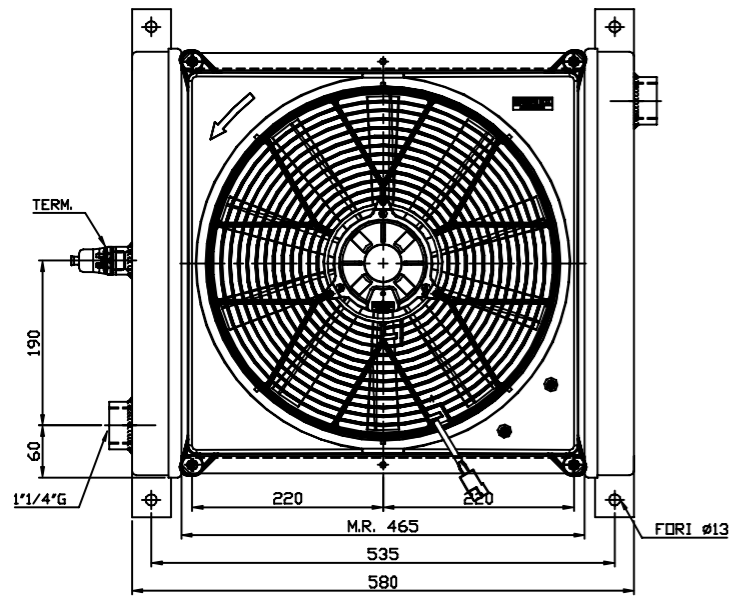

Vcc

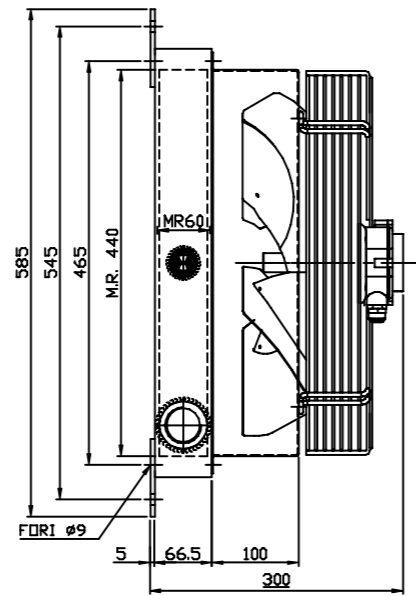
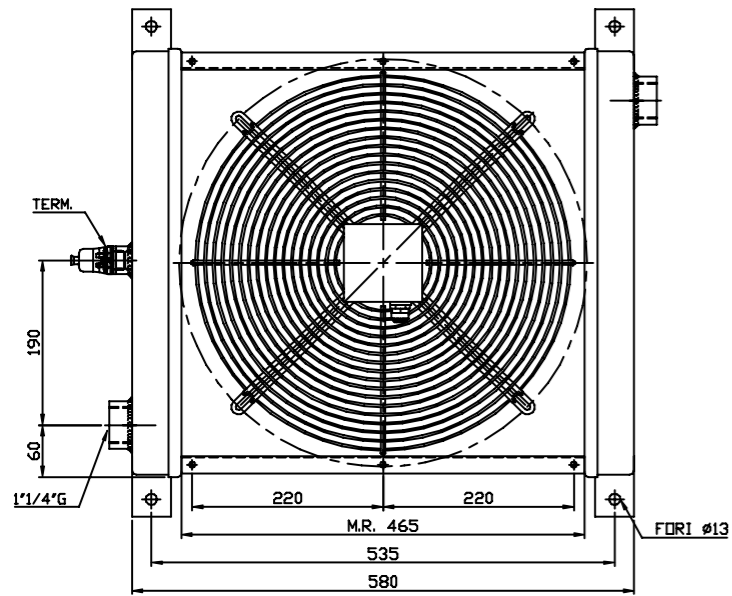

Vac

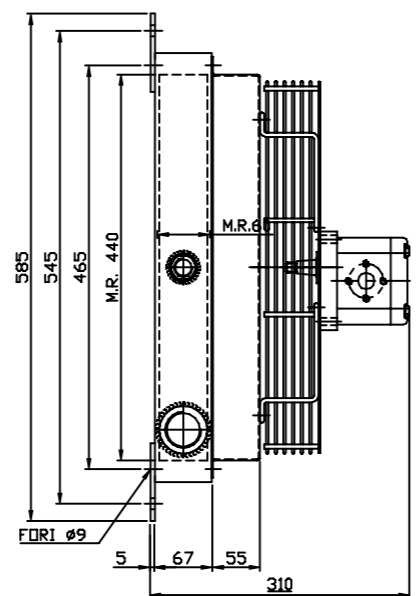
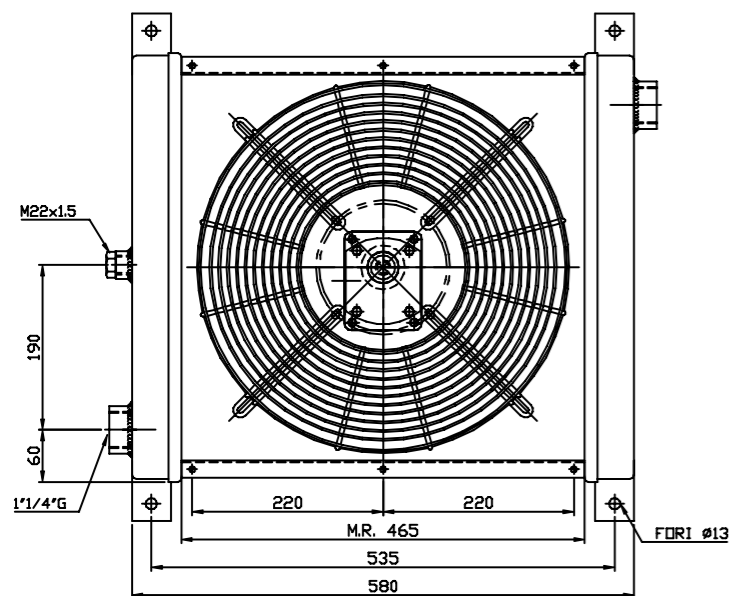

GR2

DATI TECNICI - TECHNICAL DATA

TENSIONE VOLTAGE	ASSORBIMENTO CURRENT	PORTATA ARIA AIR FLOW	PROTEZIONE PROTECTION	Ø
V	A	m ³ /h	IP	mm
12	18,1	3220	68	385
24	8	3080	68	385
230 Hz 50/60	0,73 / 1,06	4235 / 4950	44	400
230/400 Hz 50/60	0,76-0,44 / 0,68-0,39	4000 / 4610	44	400
Predisposizione GR2 - Prepared for GR2			/	400

DIAGRAMMA DI RENDIMENTO - PERFORMANCE DIAGRAM



DIAGRAMMA PERDITE DI CARICO - PRESSURE DROP DIAGRAM



Portata olio - Oil flow: 40-200 lt/1'

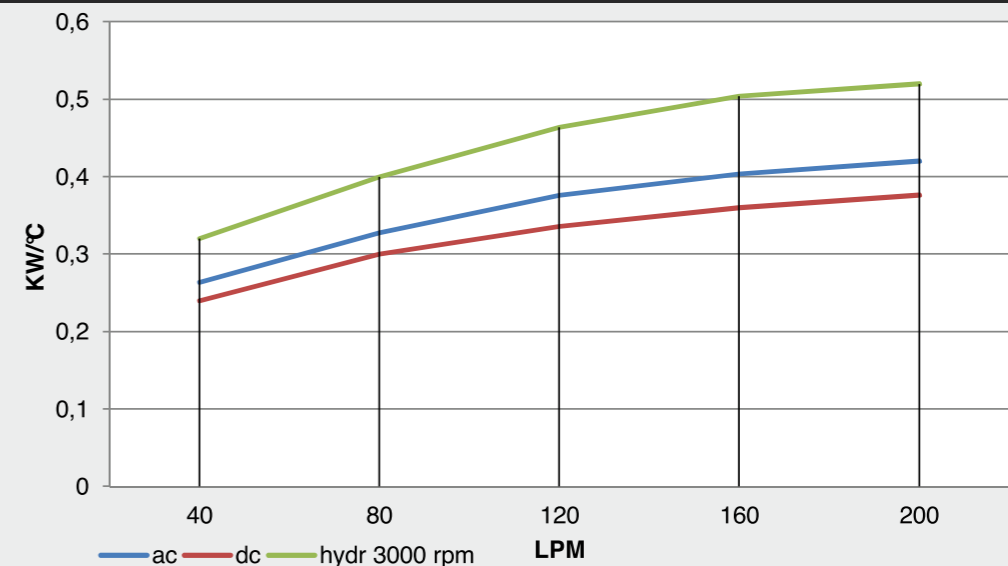
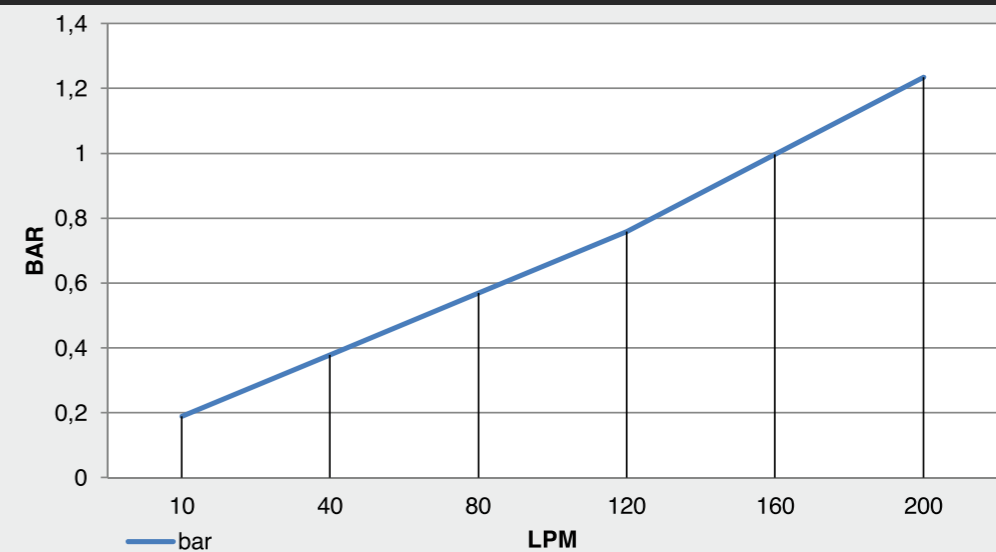
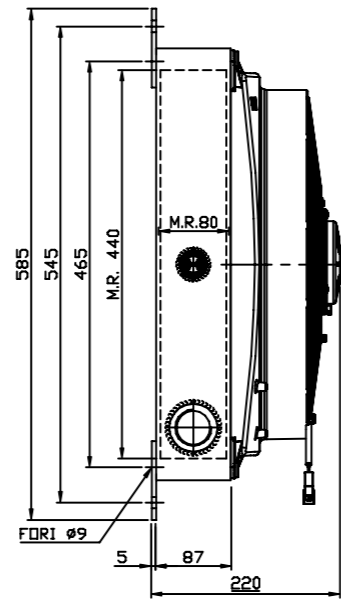
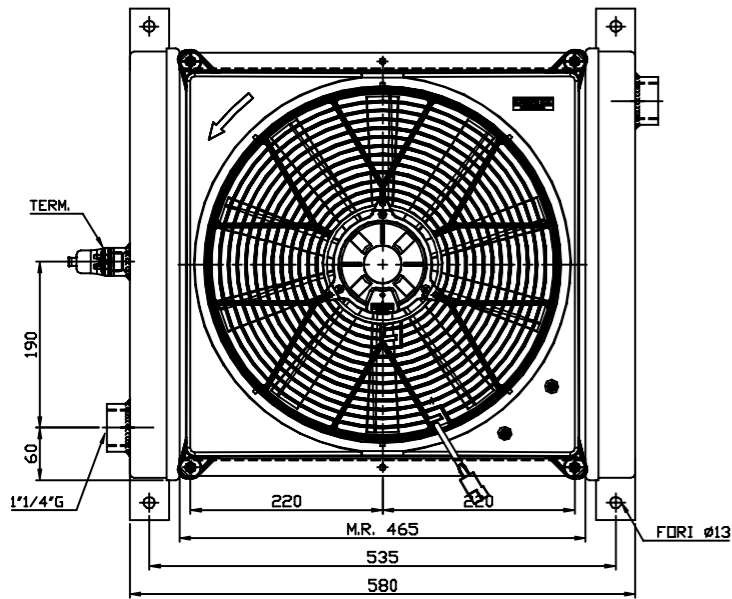

Vcc

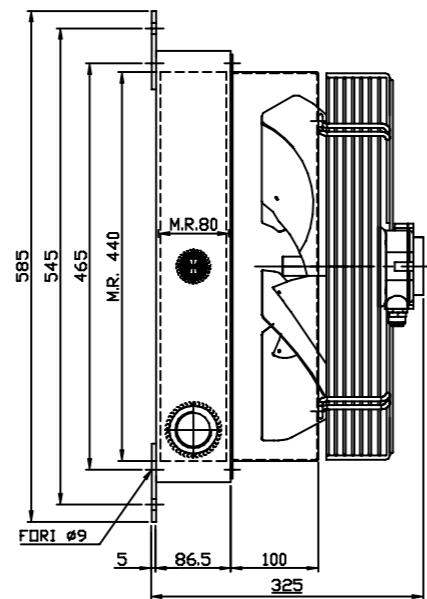
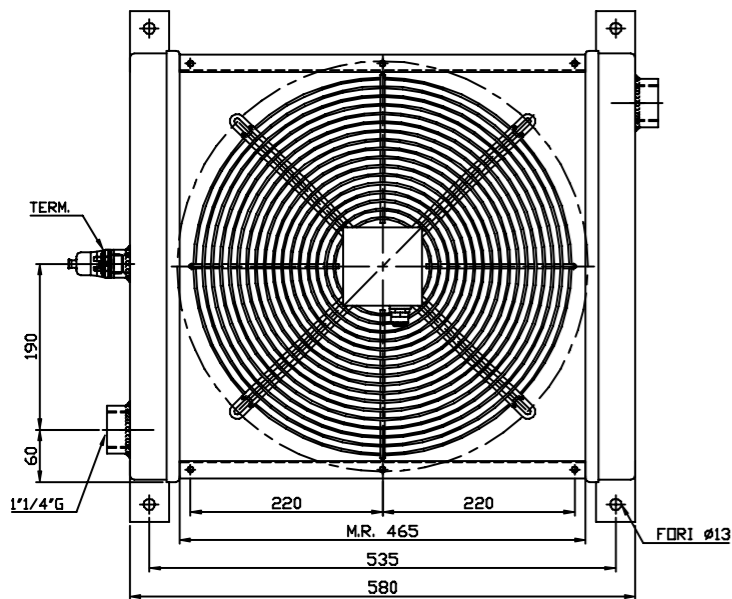

Vac

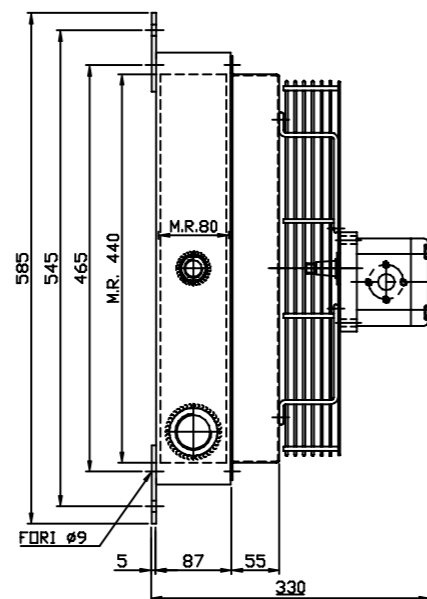
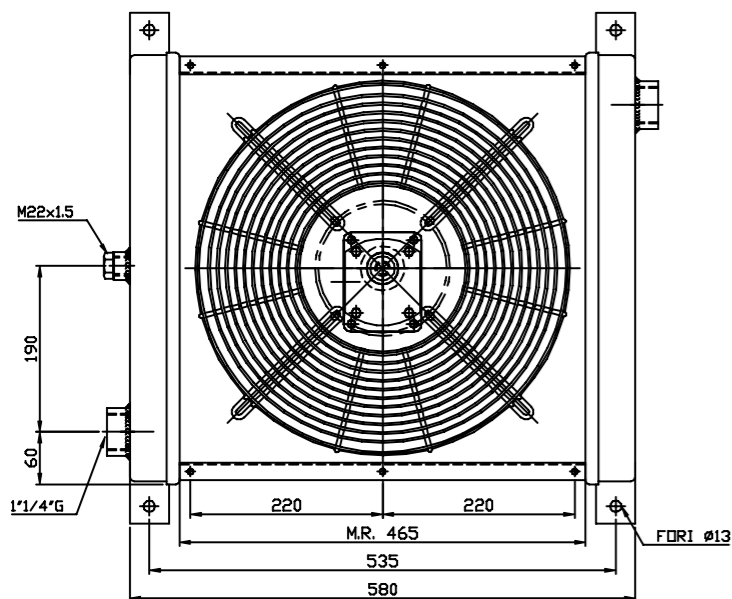

GR2

DATI TECNICI - TECHNICAL DATA

TENSIONE VOLTAGE	ASSORBIMENTO CURRENT	PORTATA ARIA AIR FLOW	PROTEZIONE PROTECTION	Ø
V	A	m ³ /h	IP	mm
12	18,1	3220	68	385
24	8	3080	68	385
230 Hz 50/60	0,73 / 1,06	4235 / 4950	44	400
230/400 Hz 50/60	0,76-0,44 / 0,68-0,39	4000 / 4610	44	400
Predisposizione GR2 - Prepared for GR2				400

DIAGRAMMA DI RENDIMENTO - PERFORMANCE DIAGRAM



DIAGRAMMA PERDITE DI CARICO - PRESSURE DROP DIAGRAM



Portata olio - Oil flow: 40-260 lt/1'

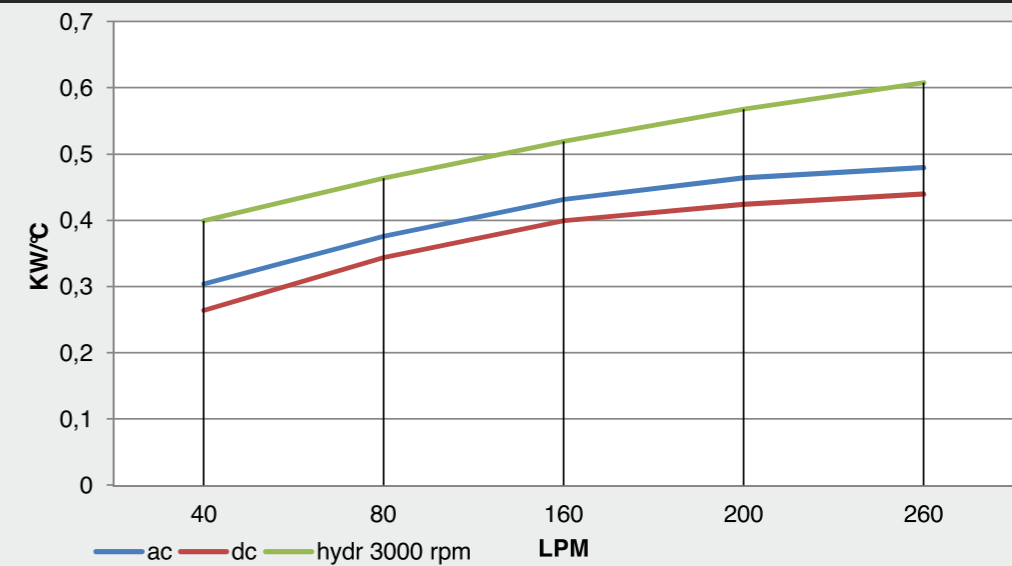
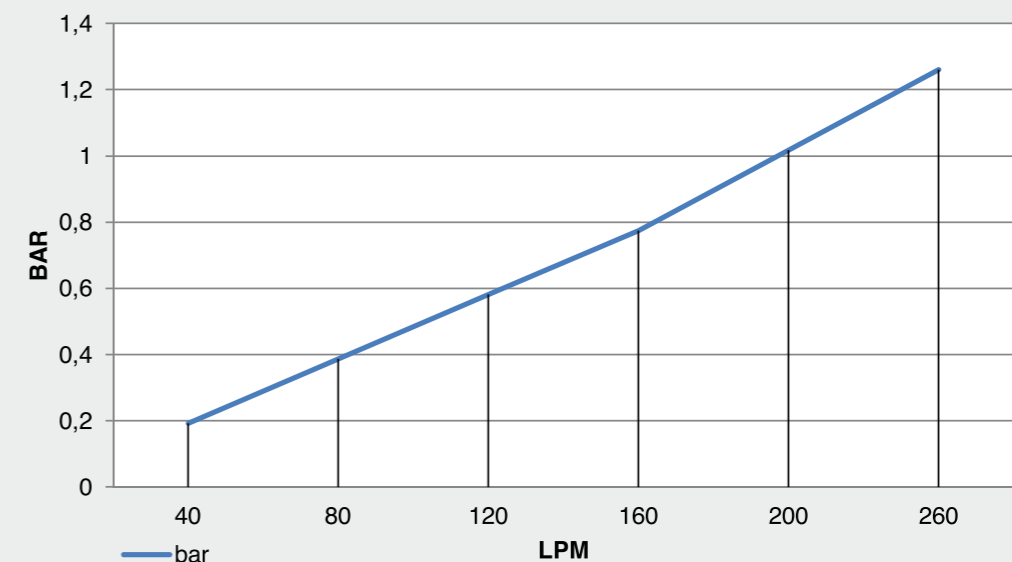
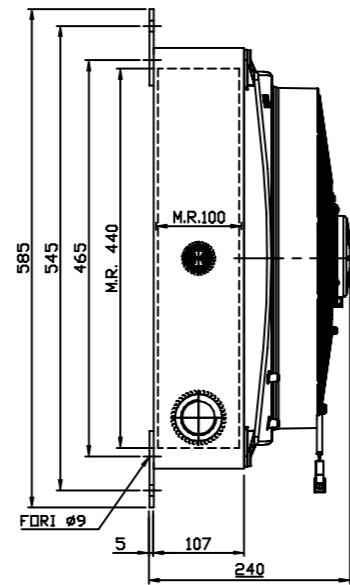
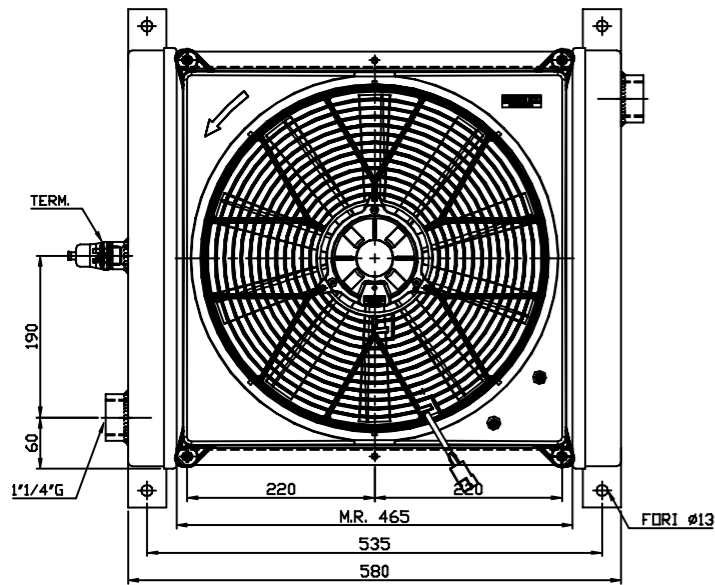

Vcc

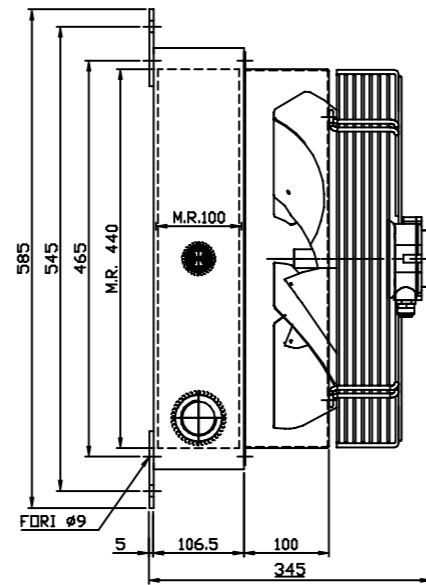
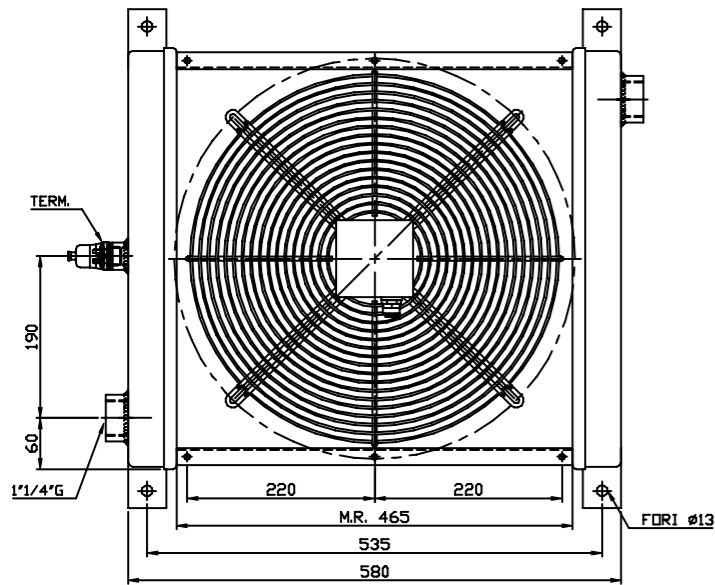

Vac

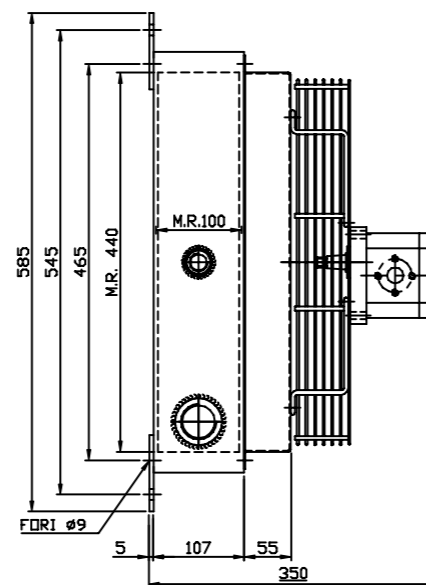
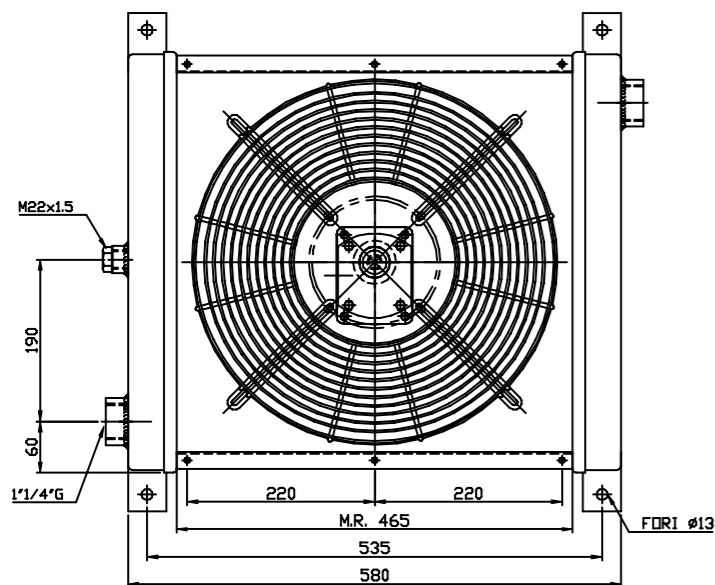

GR2

DATI TECNICI - TECHNICAL DATA

TENSIONE VOLTAGE	ASSORBIMENTO CURRENT	PORTATA ARIA AIR FLOW	PROTEZIONE PROTECTION	Ø
V	A	m ³ /h	IP	mm
12	18,1	3220	68	385
24	8	3080	68	385
230 Hz 50/60	0,73 / 1,06	4235 / 4950	44	400
230/400 Hz 50/60	0,76-0,44 / 0,68-0,39	4000 / 4610	44	400
Predisposizione GR2 - Prepared for GR2			/	400

DIAGRAMMA DI RENDIMENTO - PERFORMANCE DIAGRAM



DIAGRAMMA PERDITE DI CARICO - PRESSURE DROP DIAGRAM



Portata olio - Oil flow: 50-330 lt/1'

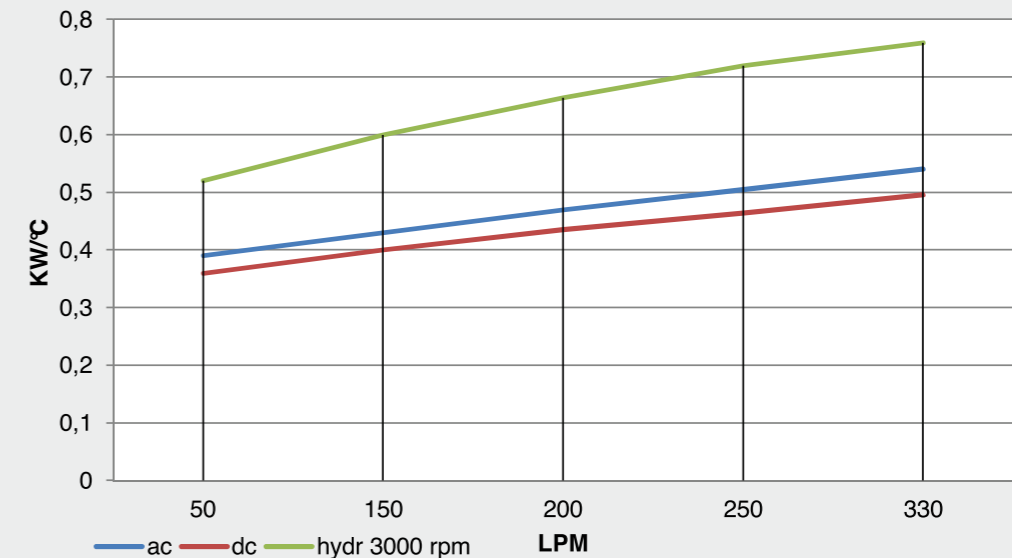
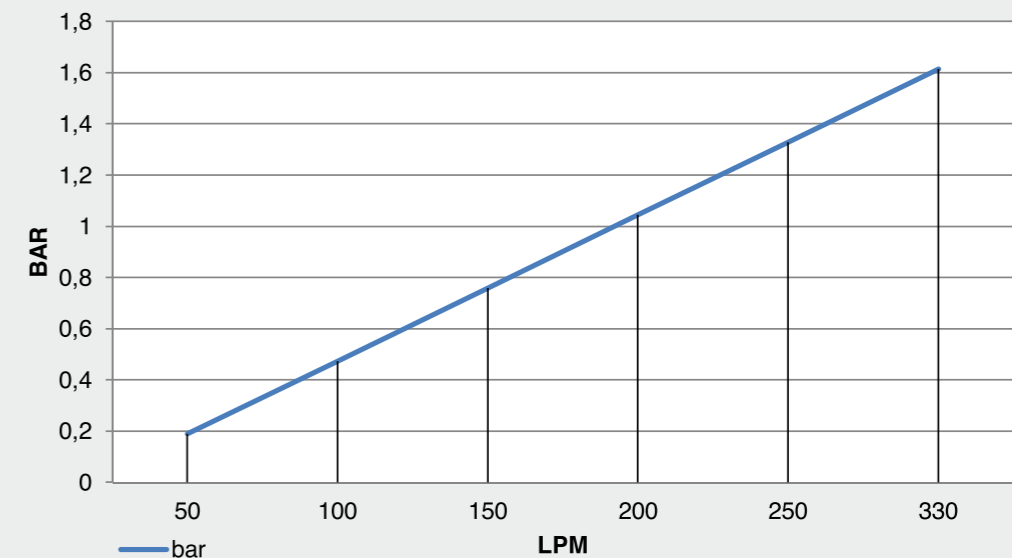
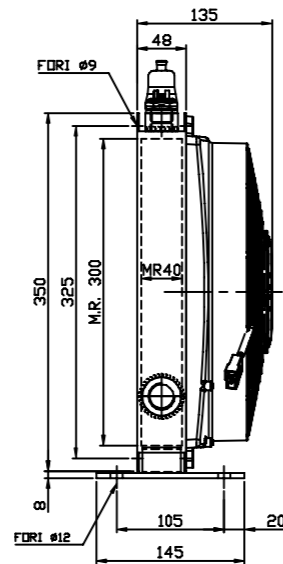
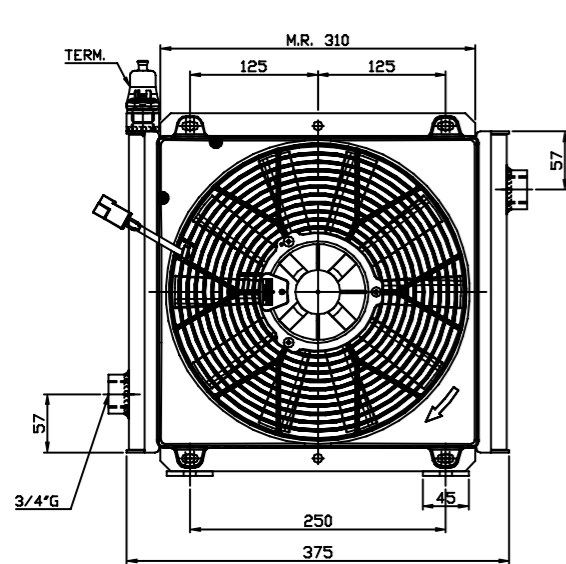

Vcc

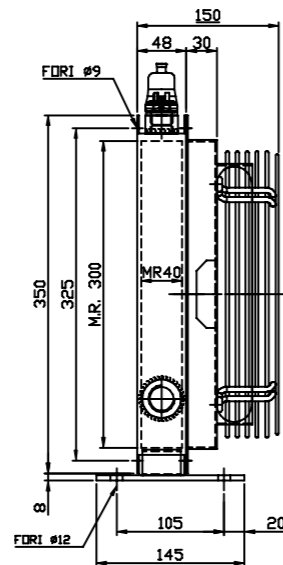
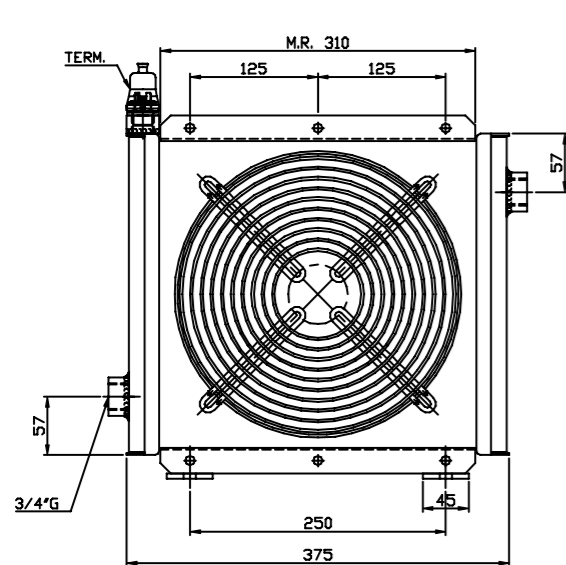

Vac

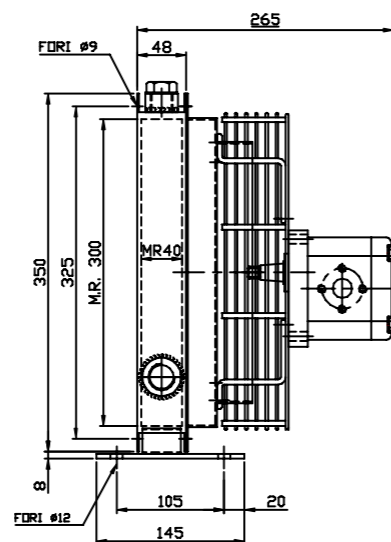
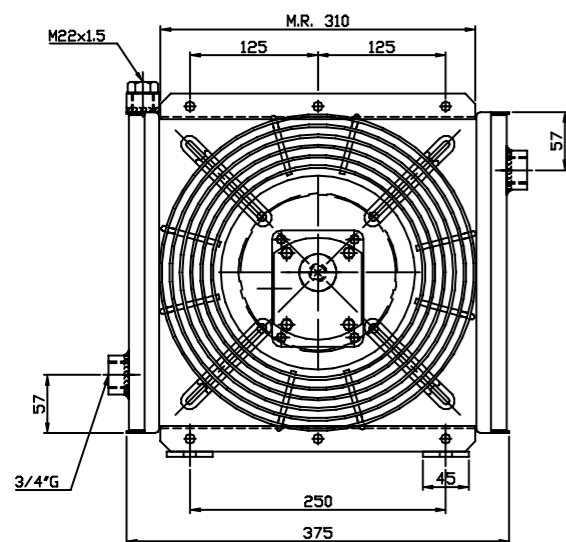

GR2

DATI TECNICI - TECHNICAL DATA

TENSIONE VOLTAGE	ASSORBIMENTO CURRENT	PORTATA ARIA AIR FLOW	PROTEZIONE PROTECTION	Ø
V	A	m ³ /h	IP	mm
12	7,8	1290	68	280
24	3,9	1270	68	280
230 Hz 50/60	0,51 / 0,66	1820 / 1970	44	250
230/400 Hz 50/60	0,34-0,20 / 0,40-0,23	1830 / 1950	44	250
Predisposizione GR2 - Prepared for GR2			/	280

DIAGRAMMA DI RENDIMENTO - PERFORMANCE DIAGRAM



DIAGRAMMA PERDITE DI CARICO - PRESSURE DROP DIAGRAM



Portata olio - Oil flow: 10-90 lt/1'

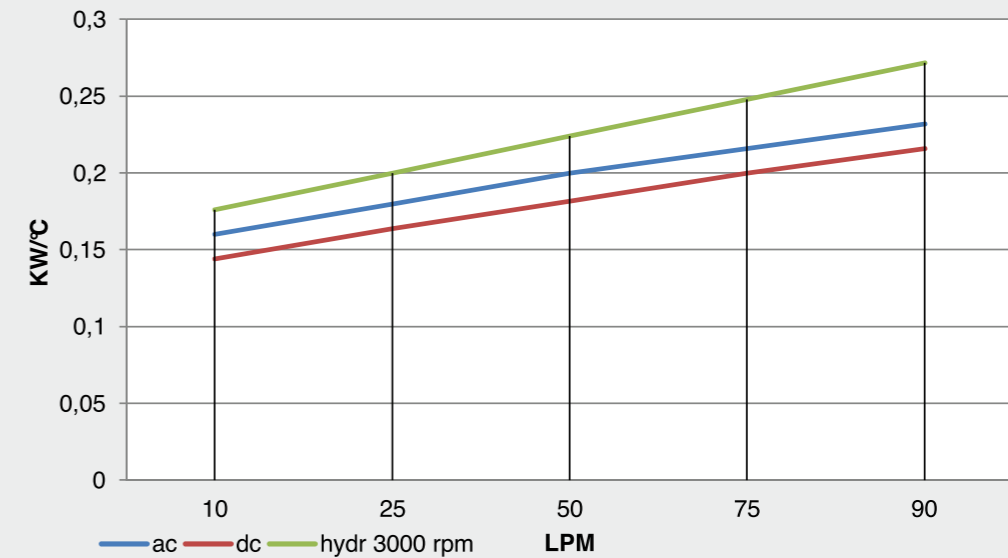
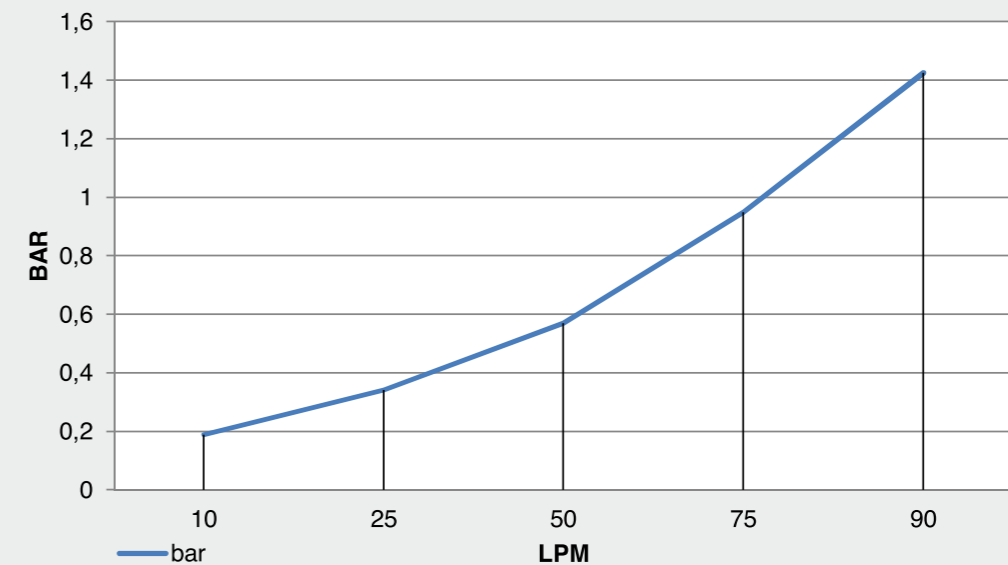
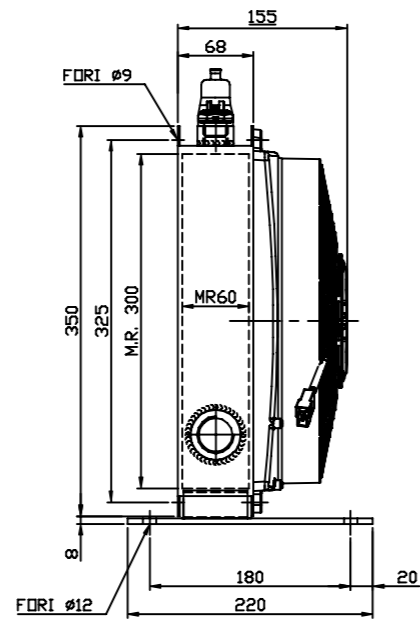
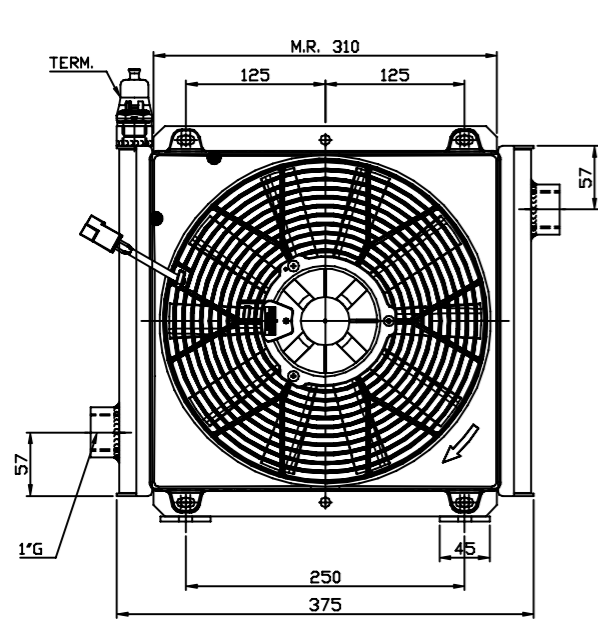

Vcc

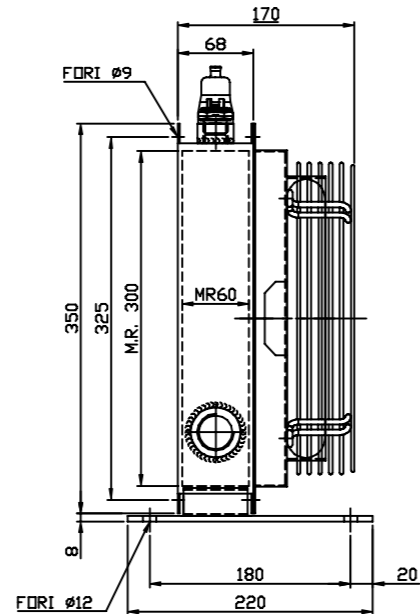
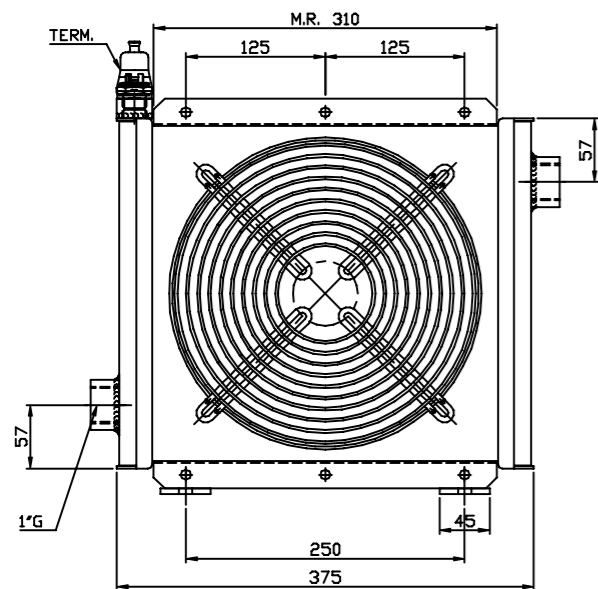

Vac

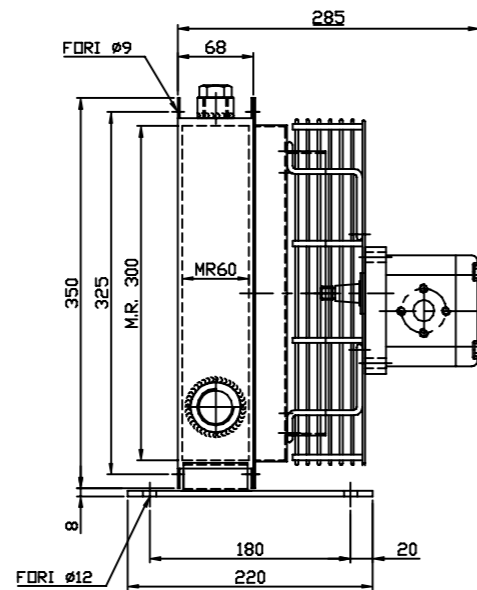
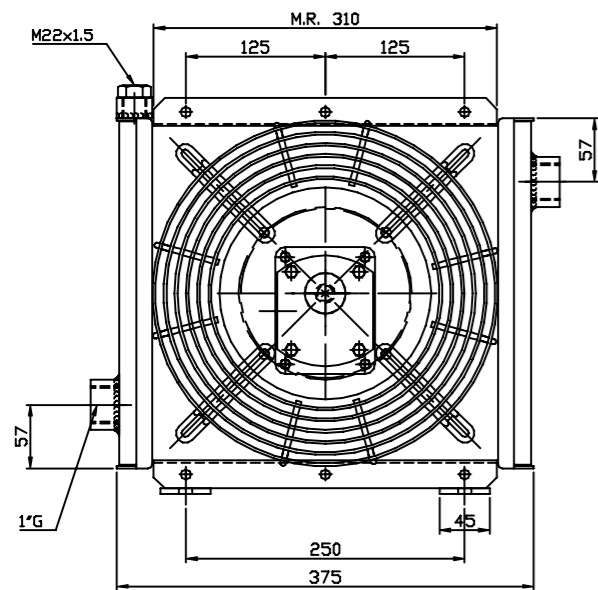

GR2

DATI TECNICI - TECHNICAL DATA

TENSIONE VOLTAGE	ASSORBIMENTO CURRENT	PORTATA ARIA AIR FLOW	PROTEZIONE PROTECTION	Ø
V	A	m ³ /h	IP	mm
12	7,8	1290	68	280
24	3,9	1270	68	280
230 Hz 50/60	0,51 / 0,66	1820 / 1970	44	250
230/400 Hz 50/60	0,34-0,20 / 0,40-0,23	1830 / 1950	44	250
Predisposizione GR2 - Prepared for GR2			/	280

DIAGRAMMA DI RENDIMENTO - PERFORMANCE DIAGRAM



DIAGRAMMA PERDITE DI CARICO - PRESSURE DROP DIAGRAM



Portata olio - Oil flow: 10-130 lt/1'

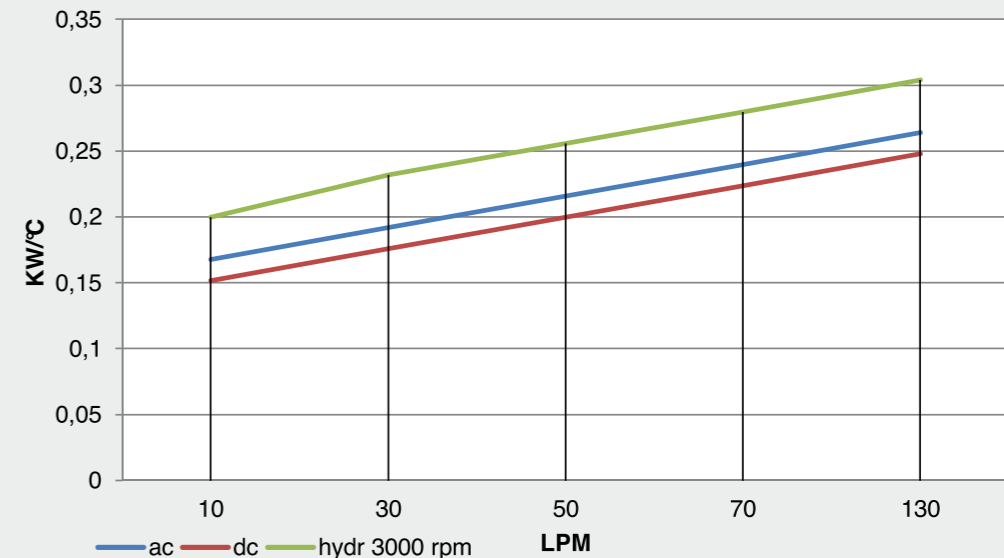
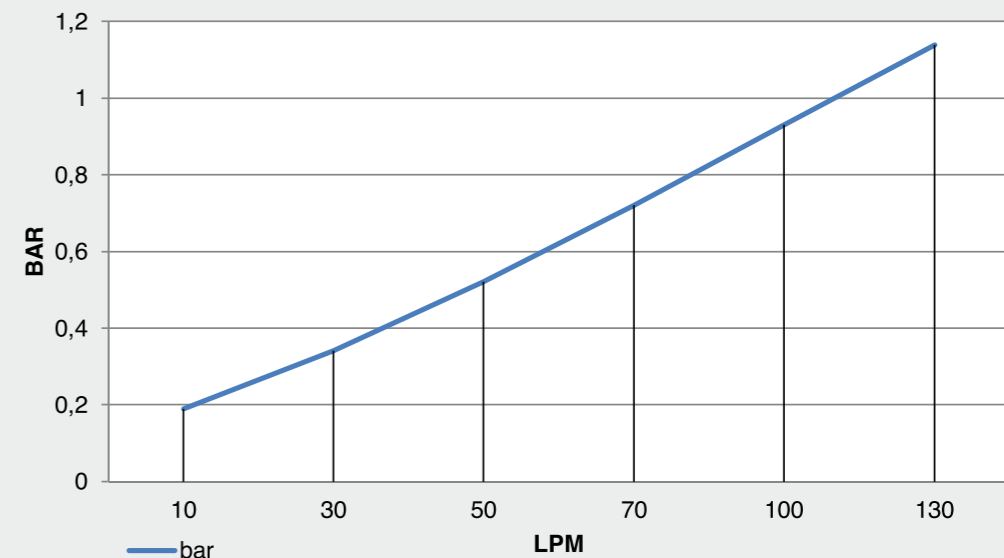
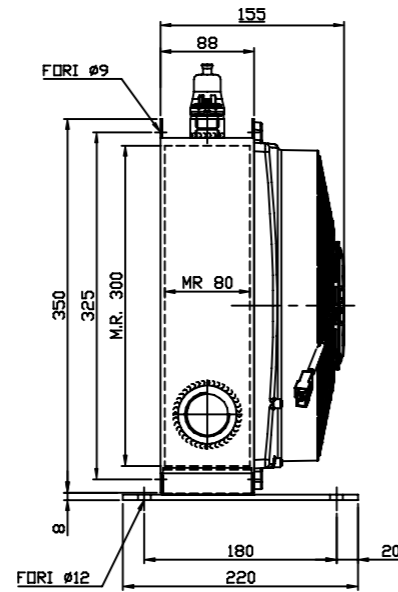
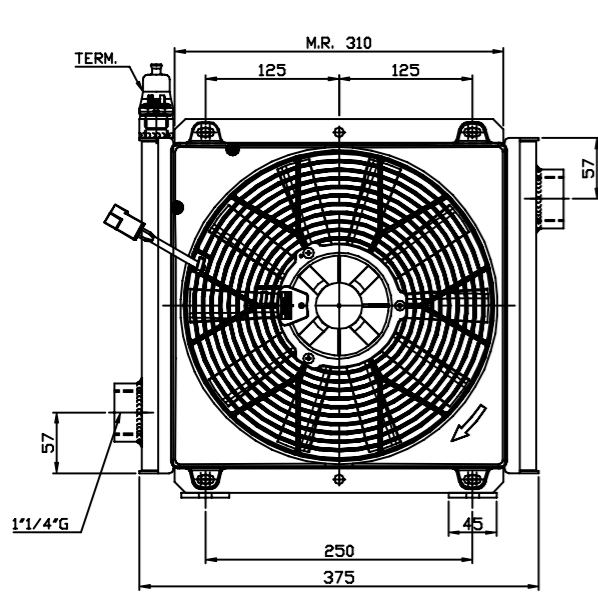

Vcc

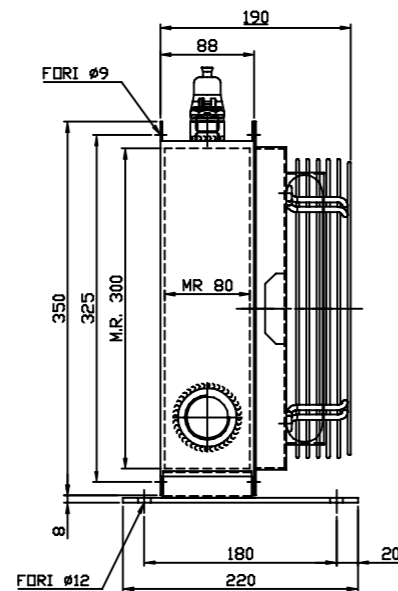
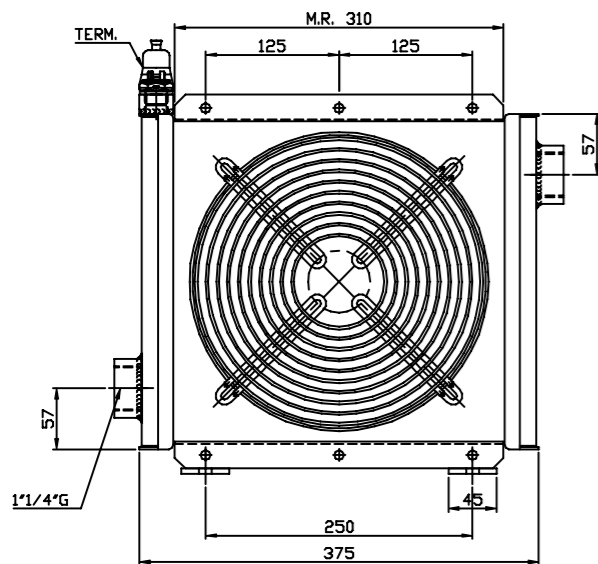

Vac

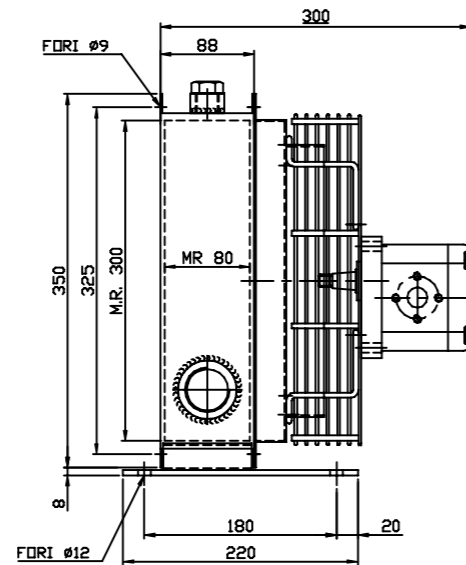
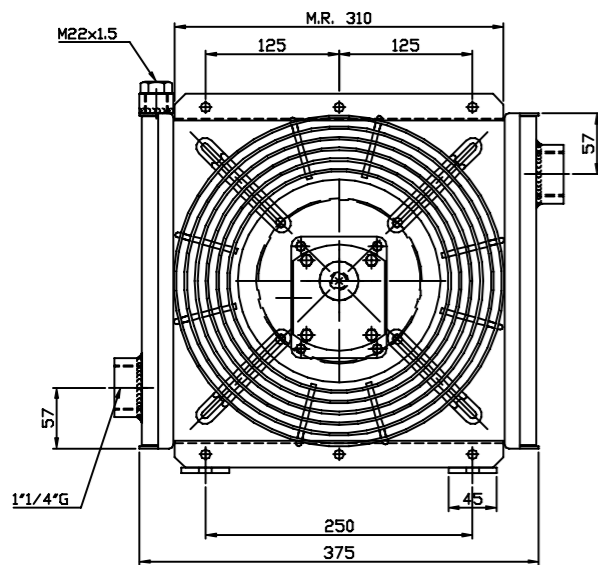

GR2

DATI TECNICI - TECHNICAL DATA

TENSIONE VOLTAGE	ASSORBIMENTO CURRENT	PORTATA ARIA AIR FLOW	PROTEZIONE PROTECTION	Ø
V	A	m ³ /h	IP	mm
12	7,8	1290	68	280
24	3,9	1270	68	280
230 Hz 50/60	0,51 / 0,66	1820 / 1970	44	250
230/400 Hz 50/60	0,34-0,20 / 0,40-0,23	1830 / 1950	44	250
Predisposizione GR2 - Prepared for GR2			/	280

DIAGRAMMA DI RENDIMENTO - PERFORMANCE DIAGRAM



DIAGRAMMA PERDITE DI CARICO - PRESSURE DROP DIAGRAM



Portata olio - Oil flow: 30-180 lt/1'

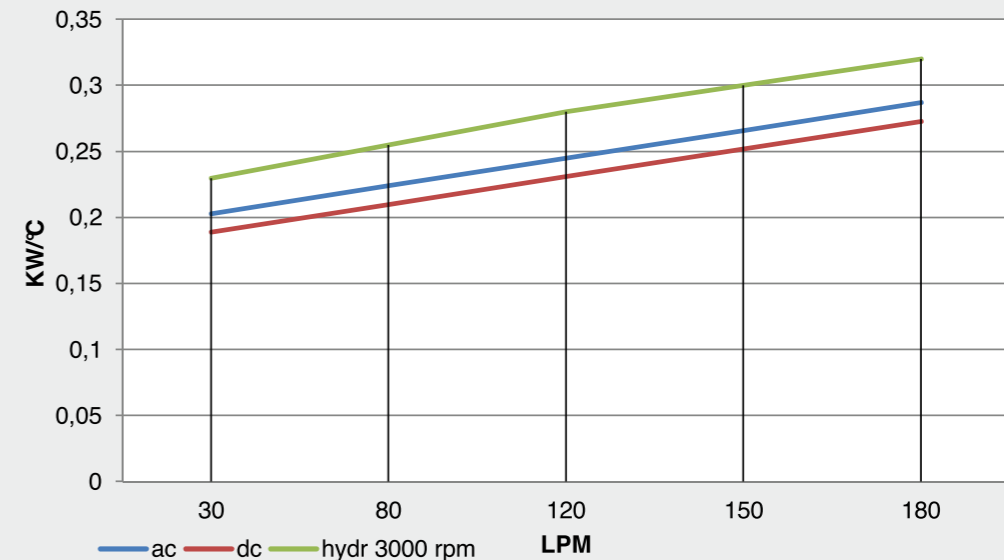
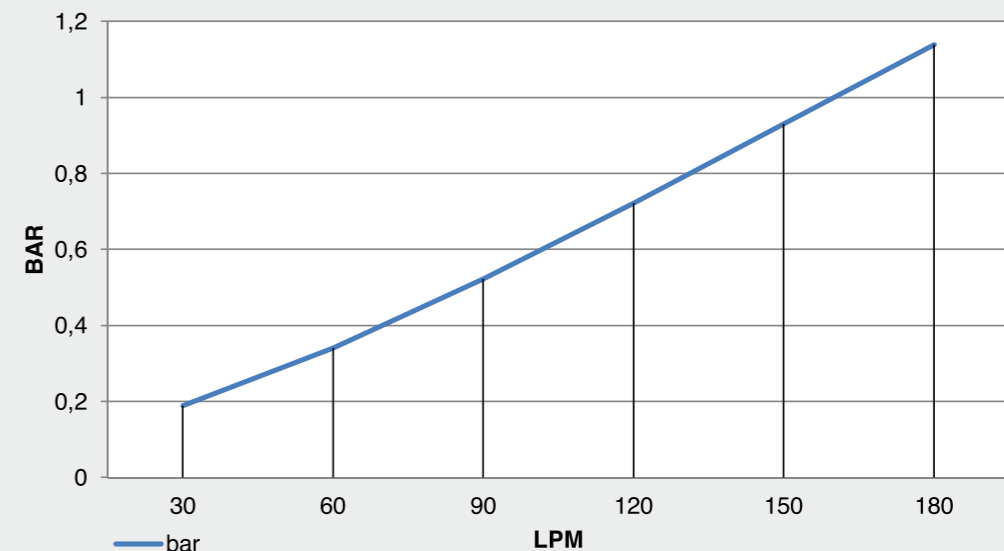
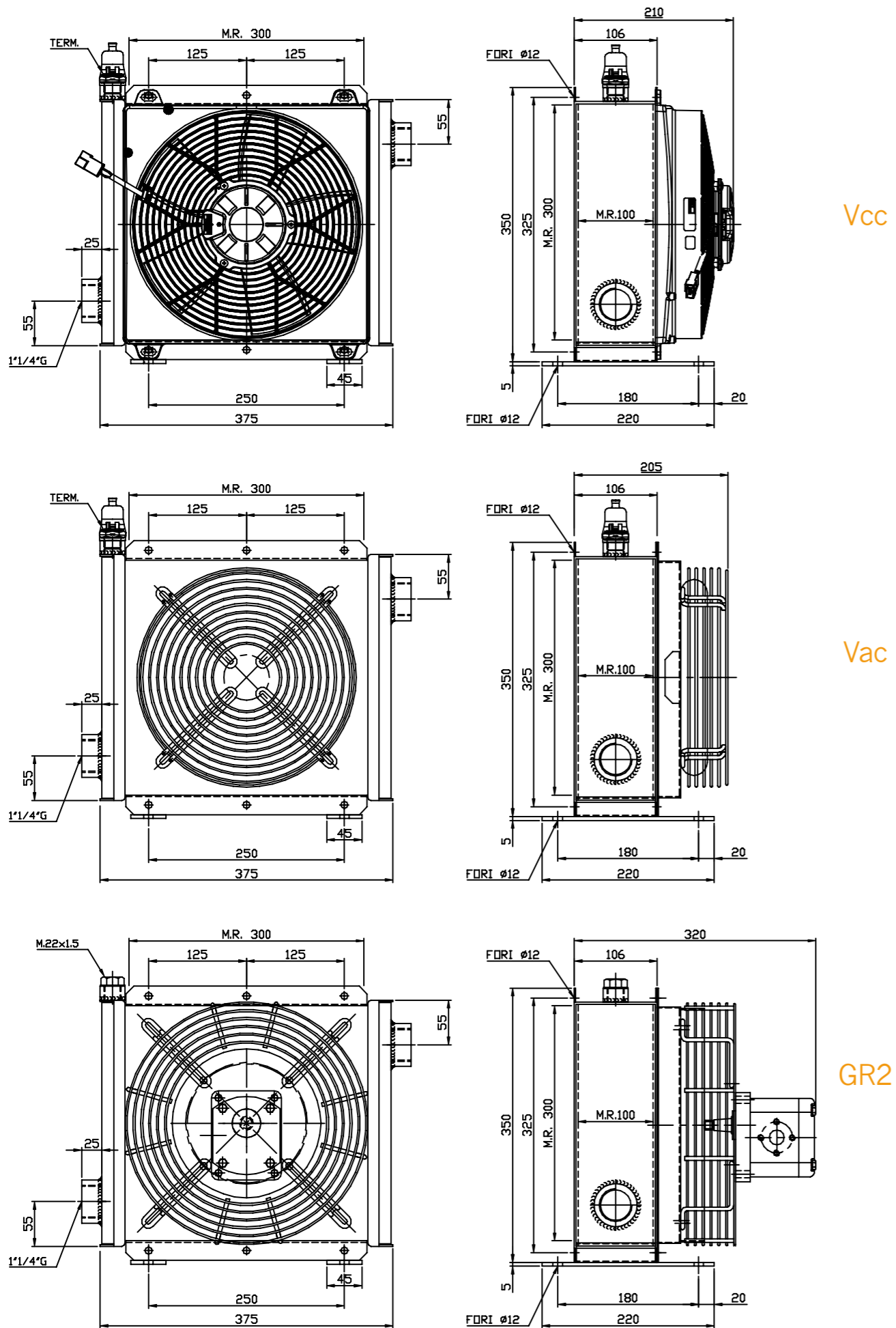

DATI TECNICI - TECHNICAL DATA

TENSIONE VOLTAGE	ASSORBIMENTO CURRENT	PORTATA ARIA AIR FLOW	PROTEZIONE PROTECTION	Ø
V	A	m ³ /h	IP	mm
12	7,8	1290	68	280
24	3,9	1270	68	280
230 Hz 50/60	0,51 / 0,66	1820 / 1970	44	250
230/400 Hz 50/60	0,34-0,20 / 0,40-0,23	1830 / 1950	44	250
Predisposizione GR2 - Prepared for GR2				280

DIAGRAMMA DI RENDIMENTO - PERFORMANCE DIAGRAM



DIAGRAMMA PERDITE DI CARICO - PRESSURE DROP DIAGRAM



Portata olio - Oil flow: 30-220 lt/1'

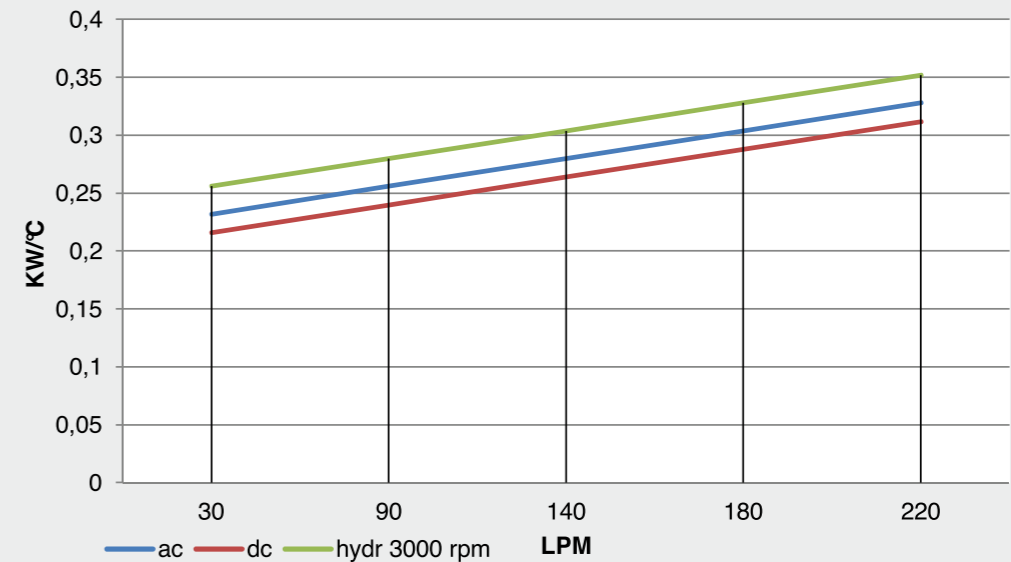
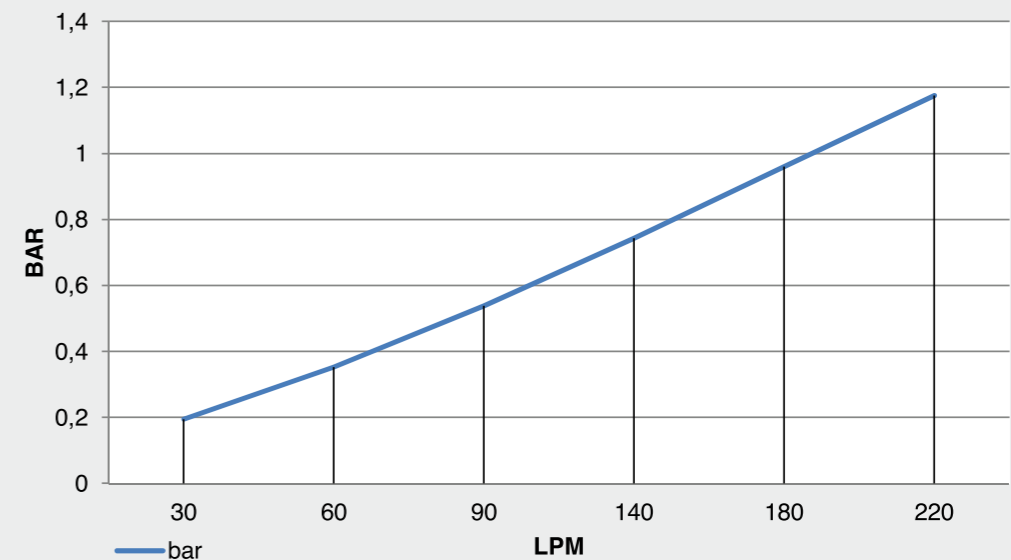
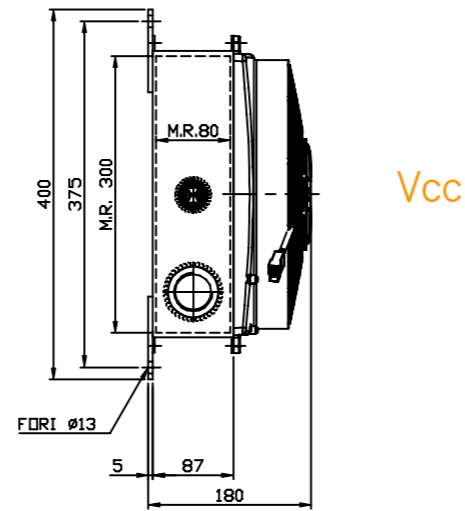
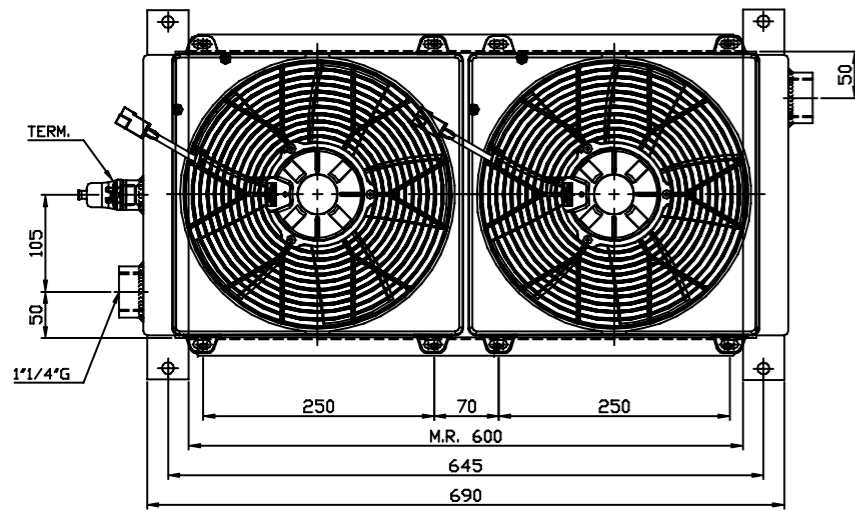

Vcc

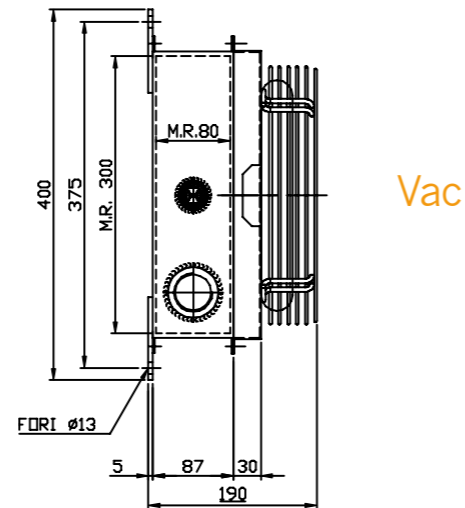
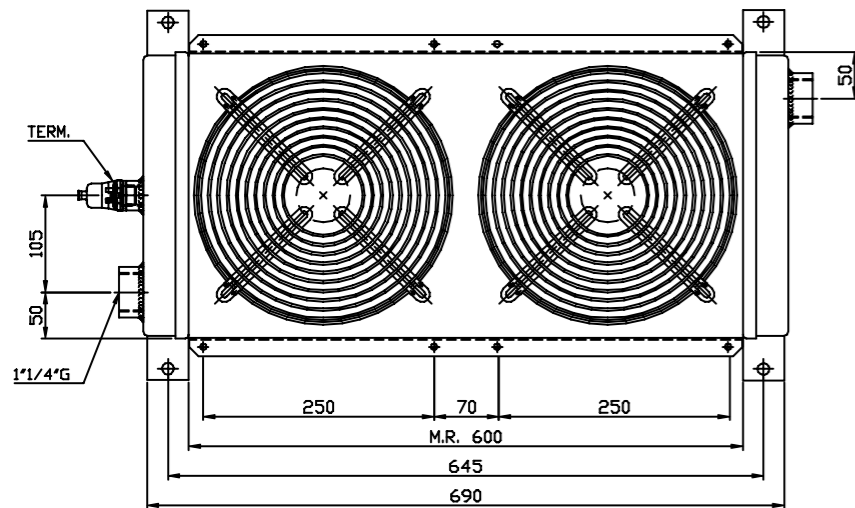

Vac

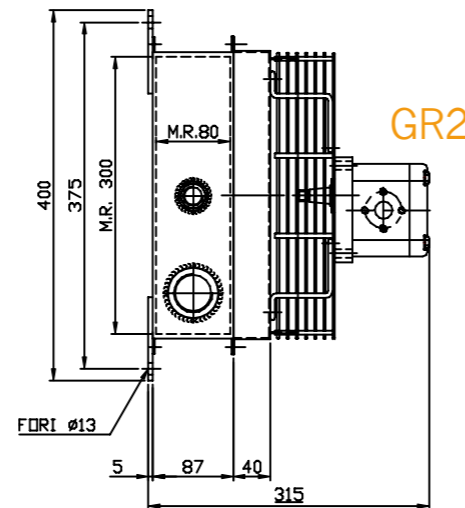
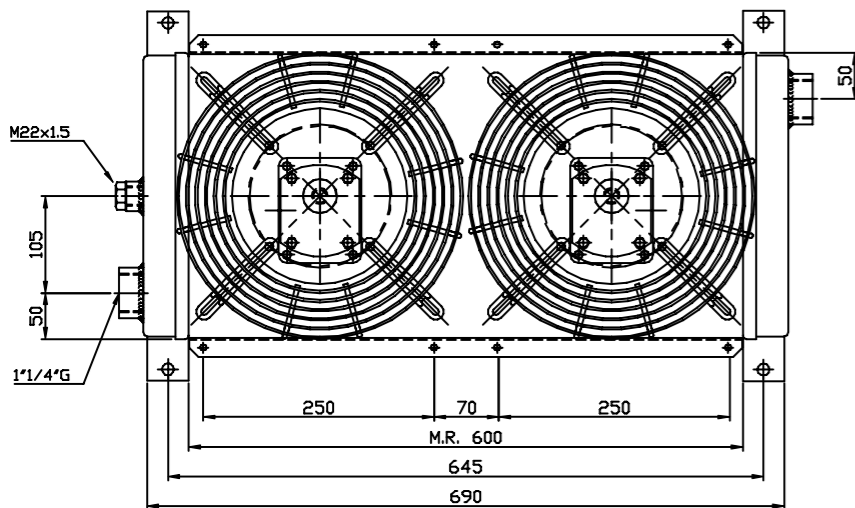

GR2

DATI TECNICI - TECHNICAL DATA

TENSIONE VOLTAGE	ASSORBIMENTO CURRENT	PORTATA ARIA AIR FLOW	PROTEZIONE PROTECTION	Ø
V	A	m ³ /h	IP	mm
12	7,8 x 2	1290 x 2	68	280 x 2
24	3,9 x 2	1270 x 2	68	280 x 2
230 Hz 50/60	0,51 / 0,66 x 2	1820 / 1970 x 2	44	250 x 2
230/400 Hz 50/60	0,34-0,20 / 0,40-0,23 x 2	1830 / 1950 x 2	44	250 x 2
Predisposizione GR2 - Prepared for GR2				280 x 2

DIAGRAMMA DI RENDIMENTO - PERFORMANCE DIAGRAM



DIAGRAMMA PERDITE DI CARICO - PRESSURE DROP DIAGRAM



Portata olio - Oil flow: 20-200 lt/1'

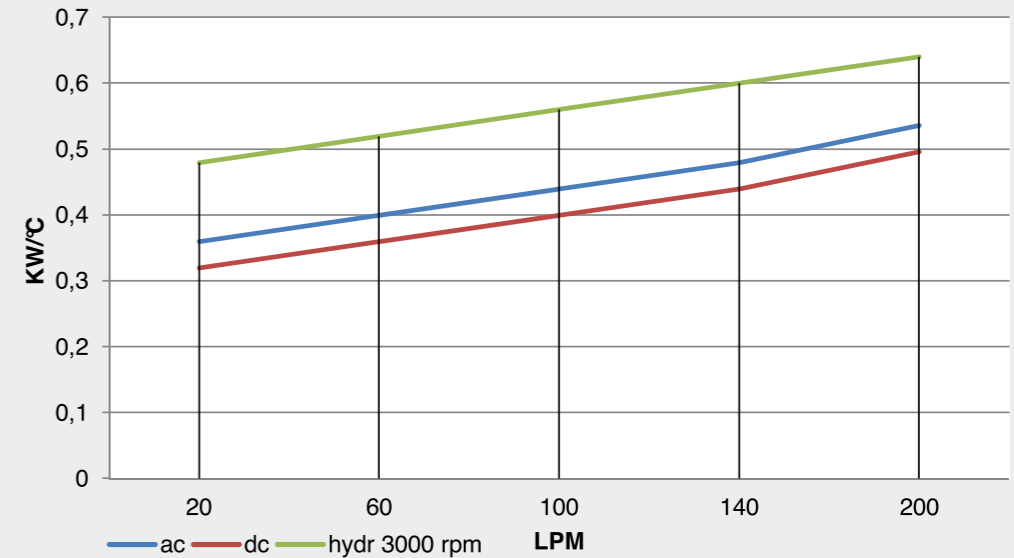
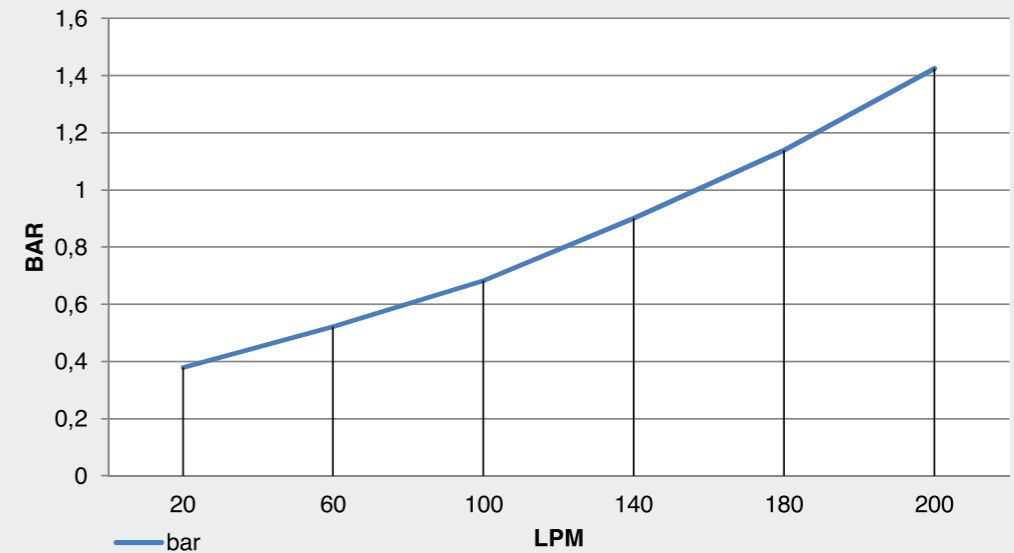
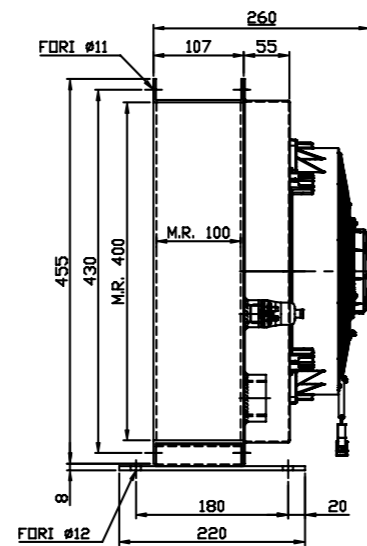
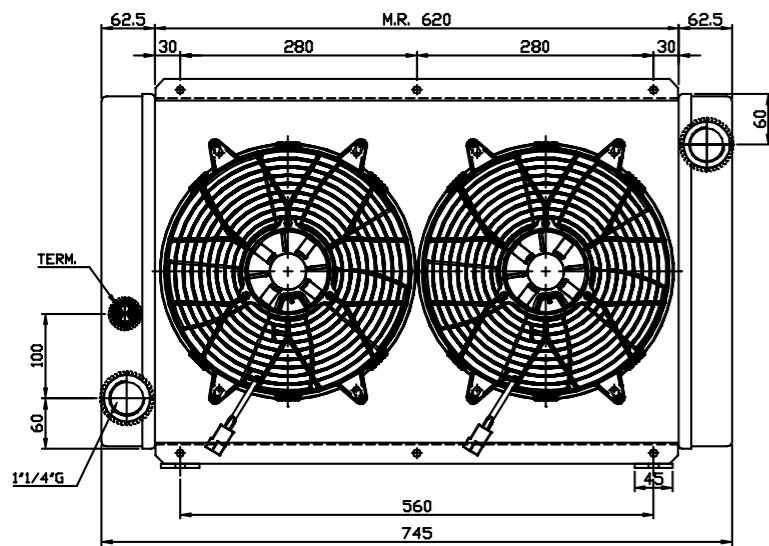

Vcc

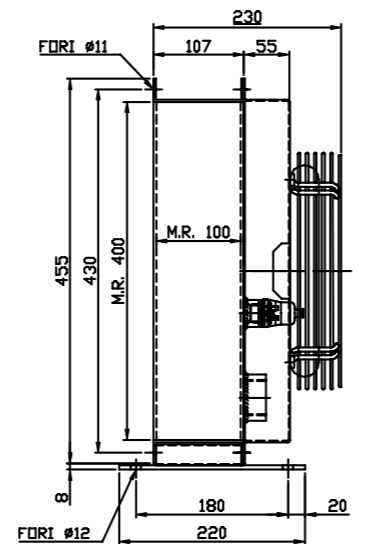
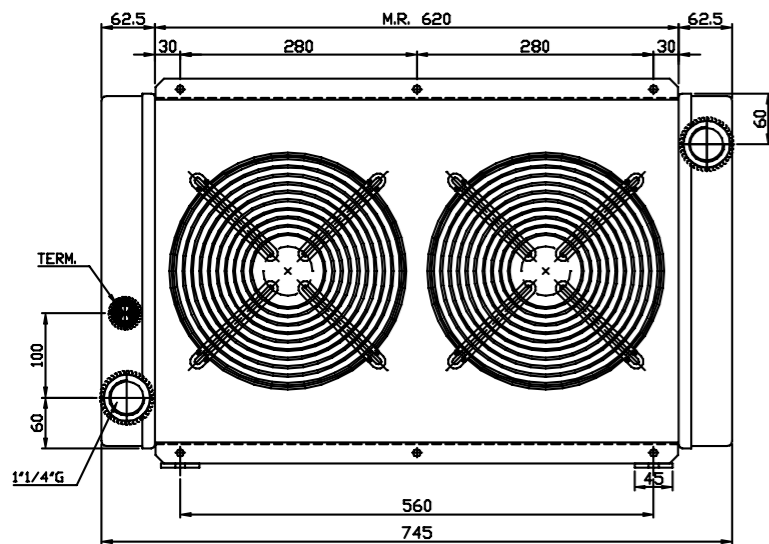

Vac

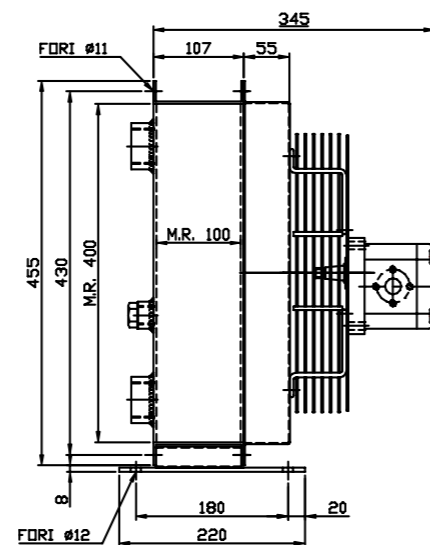
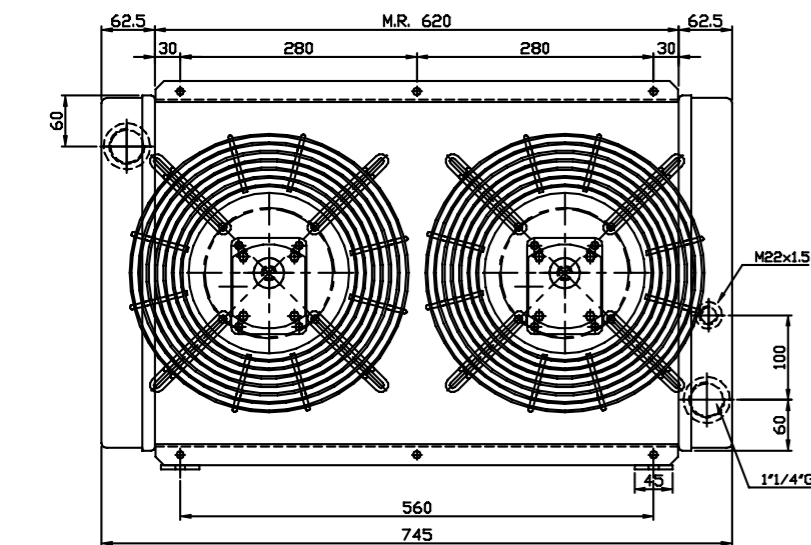

GR2

DATI TECNICI - TECHNICAL DATA

TENSIONE VOLTAGE	ASSORBIMENTO CURRENT	PORTATA ARIA AIR FLOW	PROTEZIONE PROTECTION	Ø
V	A	m ³ /h	IP	mm
12	16,6 x 2	2010 x 2	68	280 x 2
24	8 x 2	2010 x 2	68	280 x 2
230 Hz 50/60	0,51 / 0,66 x 2	1820 / 1970 x 2	44	250 x 2
230/400 Hz 50/60	0,34-0,20 / 0,40-0,23 x 2	1830 / 1950 x 2	44	250 x 2
Predisposizione GR2 - Prepared for GR2			/	300 x 2

DIAGRAMMA DI RENDIMENTO - PERFORMANCE DIAGRAM



DIAGRAMMA PERDITE DI CARICO - PRESSURE DROP DIAGRAM



Portata olio - Oil flow: 20-260 lt/1'

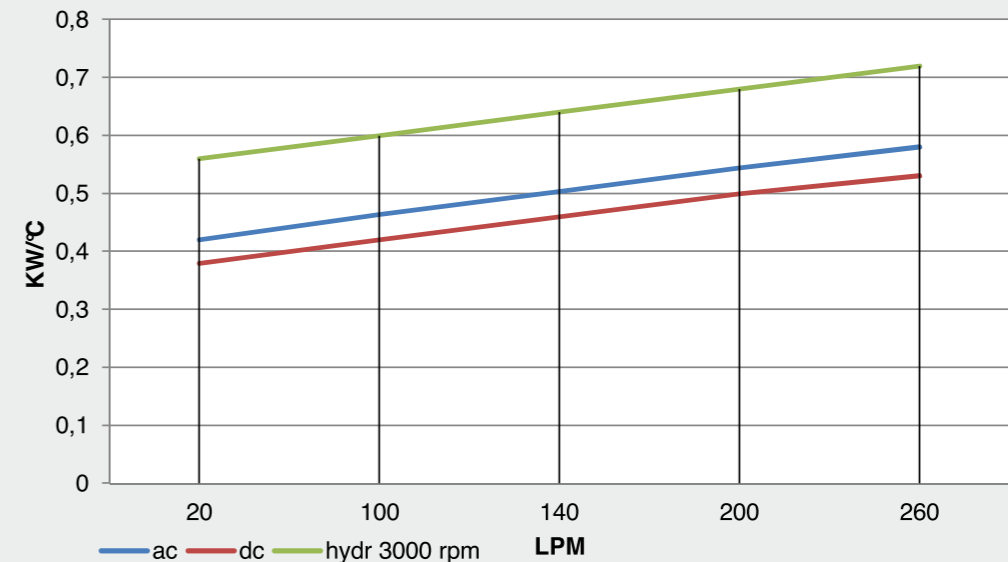
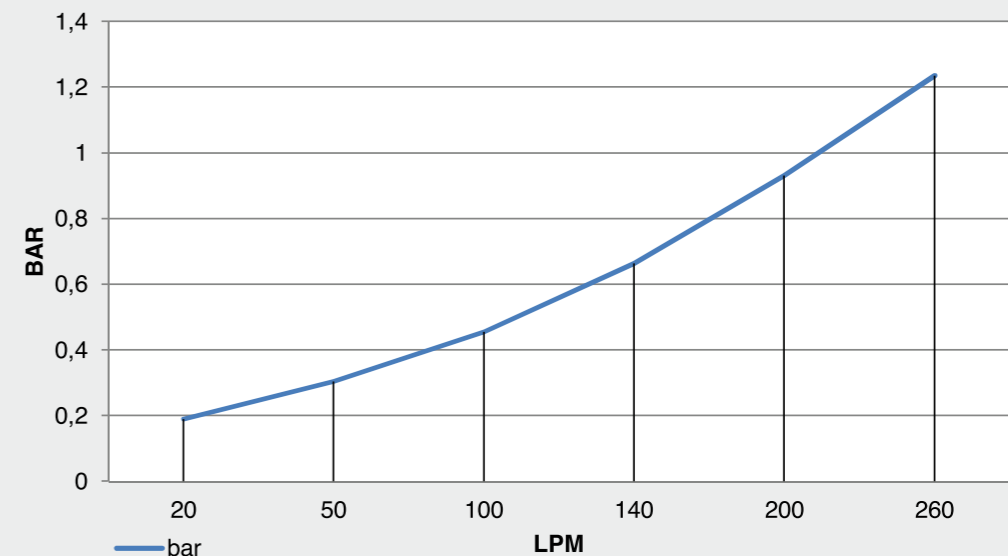
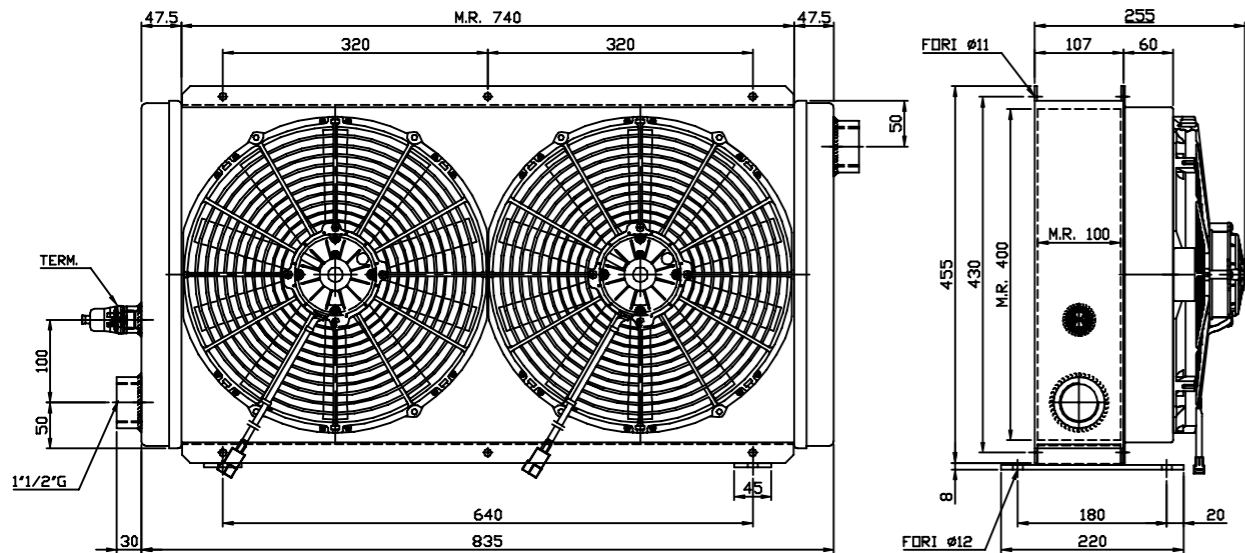

Vcc

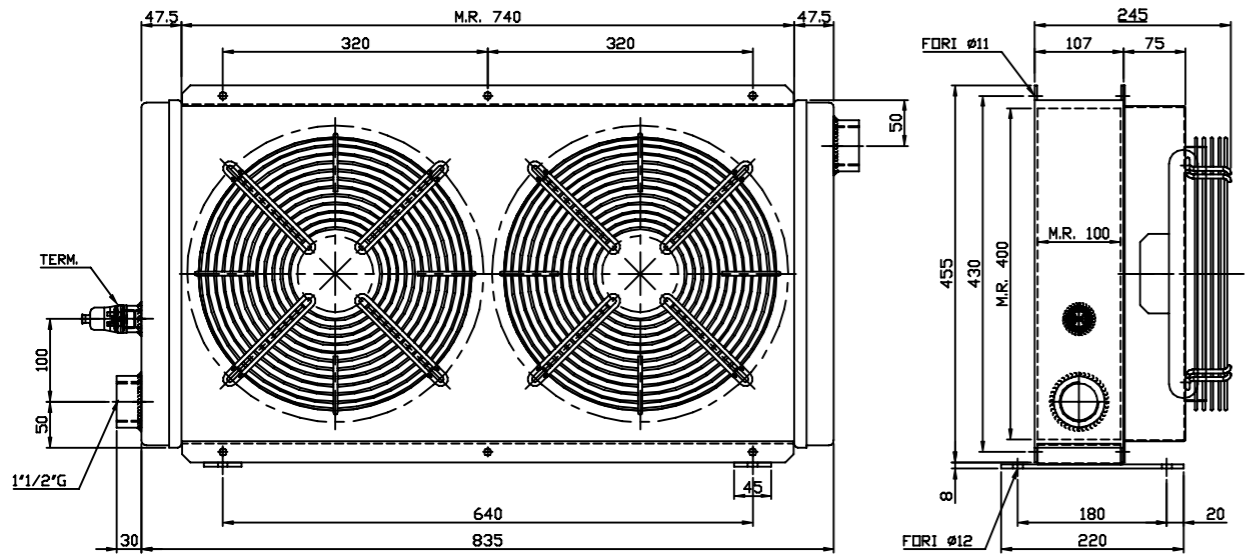

Vac

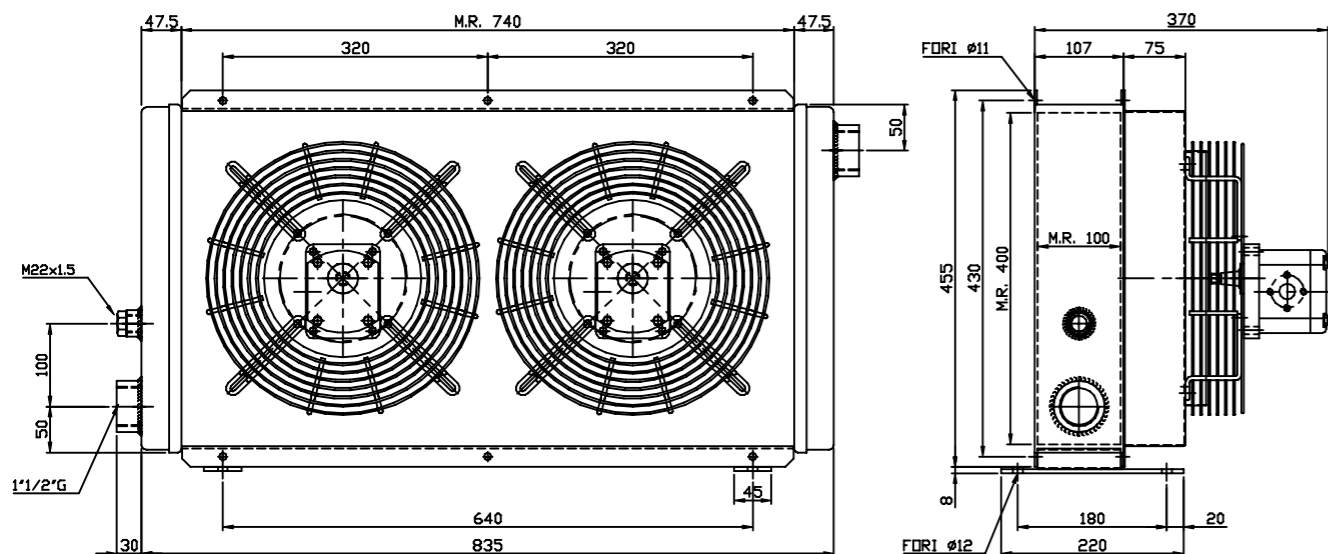

GR2

DATI TECNICI - TECHNICAL DATA

TENSIONE VOLTAGE	ASSORBIMENTO CURRENT	PORTATA ARIA AIR FLOW	PROTEZIONE PROTECTION	Ø
V	A	m ³ /h	IP	mm
12	18,7 x 2	2840 x 2	68	350 x 2
24	10,1 x 2	2810 x 2	68	350 x 2
230 Hz 50/60	1,1 / 1,55 x 2	3410 / 3740 x 2	44	300 x 2
230/400 Hz 50/60	0,62-0,36 / 0,83-0,48 x 2	3130 / 3350 x 2	44	300 x 2
Predisposizione GR2 - Prepared for GR2				300 x 2

DIAGRAMMA DI RENDIMENTO - PERFORMANCE DIAGRAM



DIAGRAMMA PERDITE DI CARICO - PRESSURE DROP DIAGRAM



Portata olio - Oil flow: 50-300 lt/1'

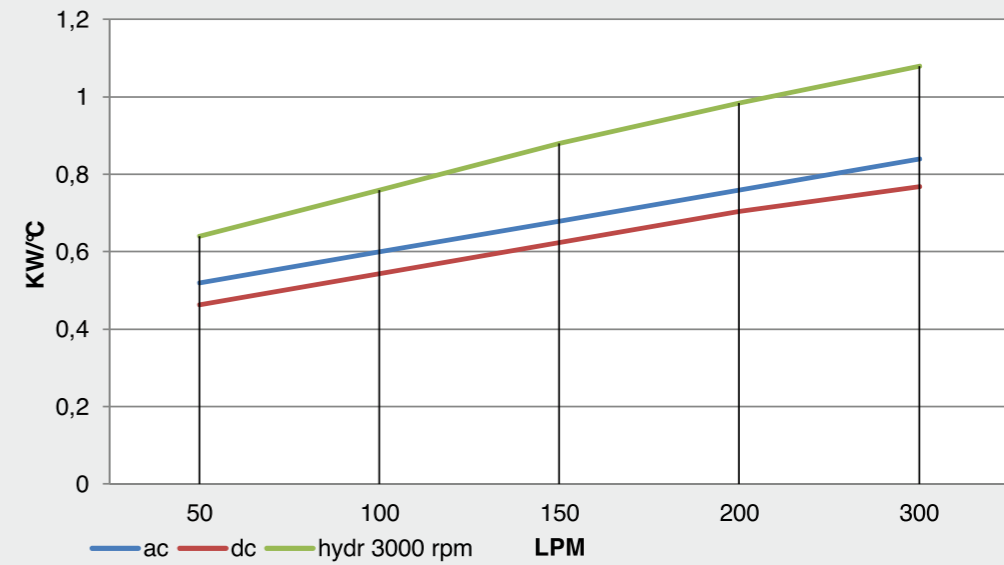
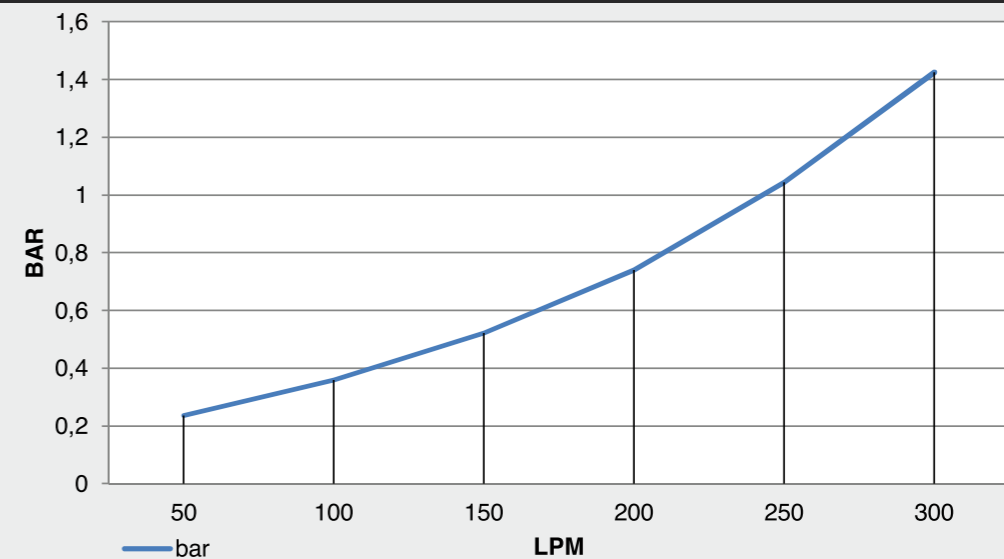
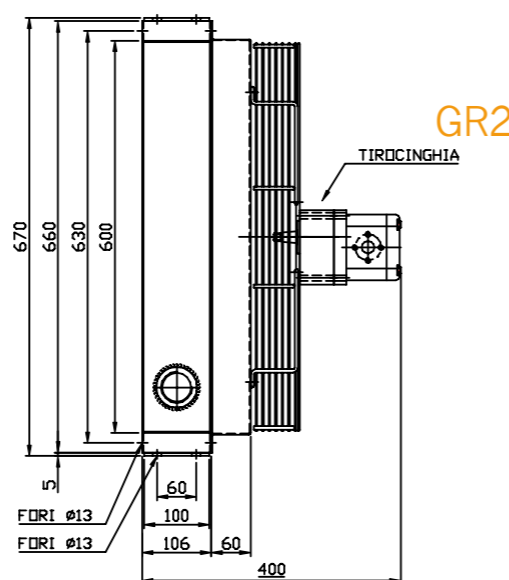
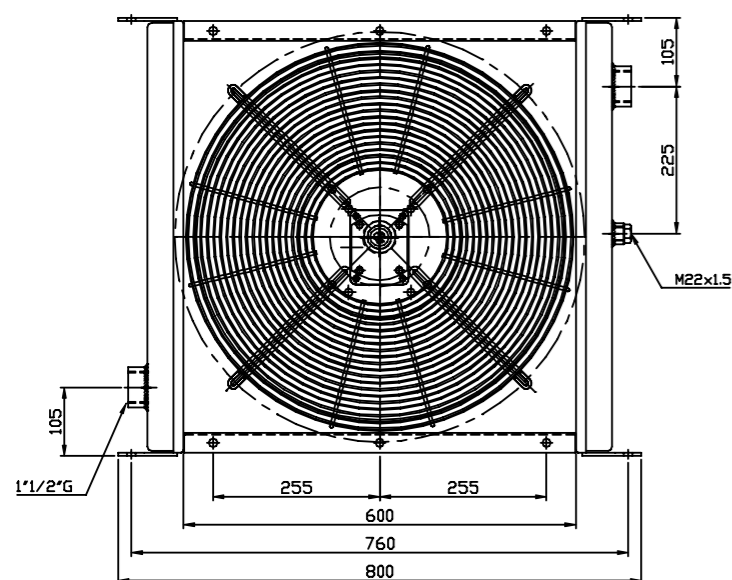
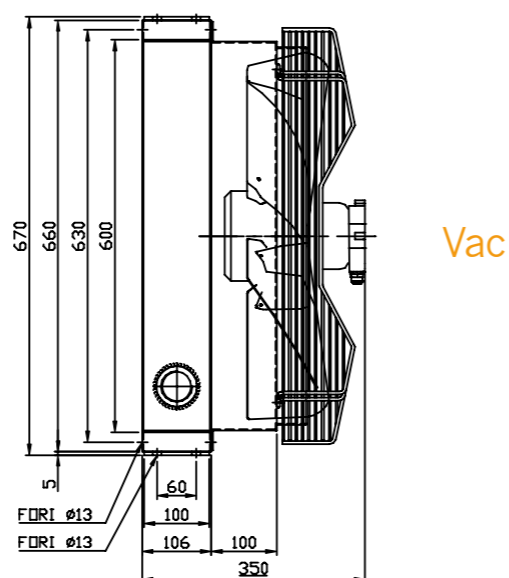
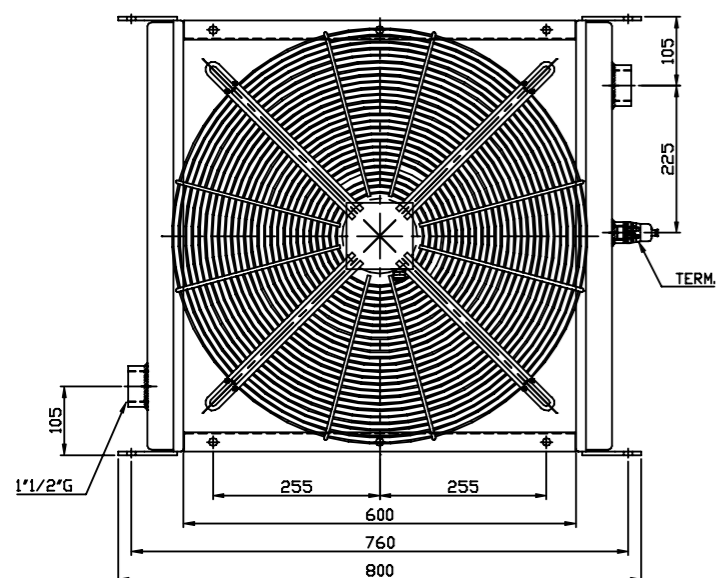
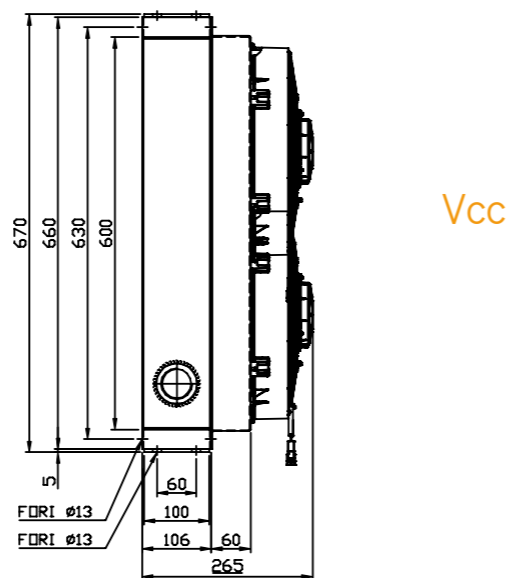
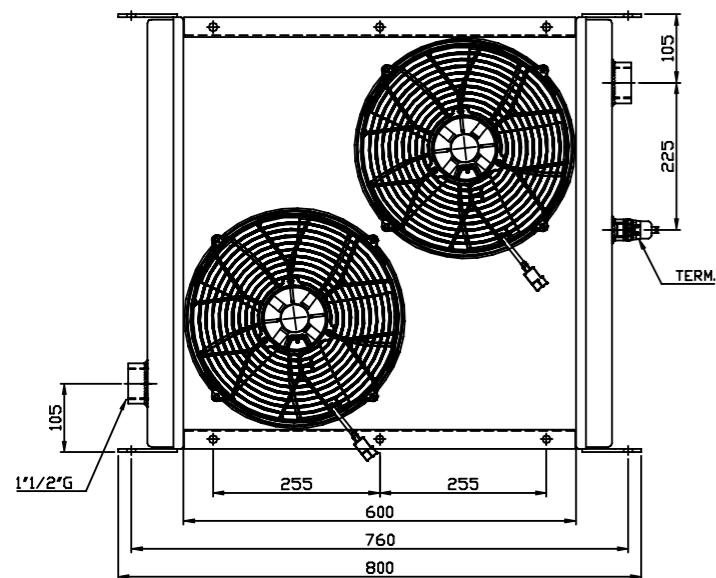

DATI TECNICI - TECHNICAL DATA

TENSIONE VOLTAGE	ASSORBIMENTO CURRENT	PORTATA ARIA AIR FLOW	PROTEZIONE PROTECTION	Ø
V	A	m ³ /h	IP	mm
12	20,7 x 2	2490 x 2	68	305 x 2
24	10 x 2	2520 x 2	68	305 x 2
230 Hz 50/60	4,15	10470	54	560
400/400 Hz 50/60	1,32 / 1,60	8910 / 10350	54	560
Predisposizione GR2 - Prepared for GR2			/	560

DIAGRAMMA DI RENDIMENTO - PERFORMANCE DIAGRAM



DIAGRAMMA PERDITE DI CARICO - PRESSURE DROP DIAGRAM



Portata olio - Oil flow: 50-400 lt/1'

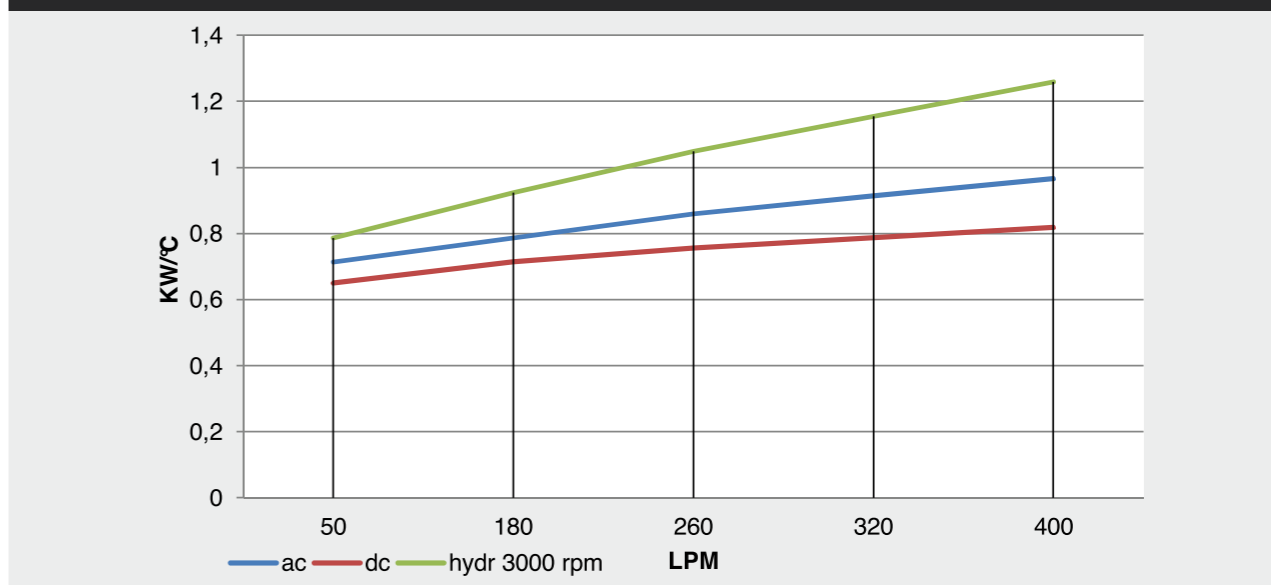
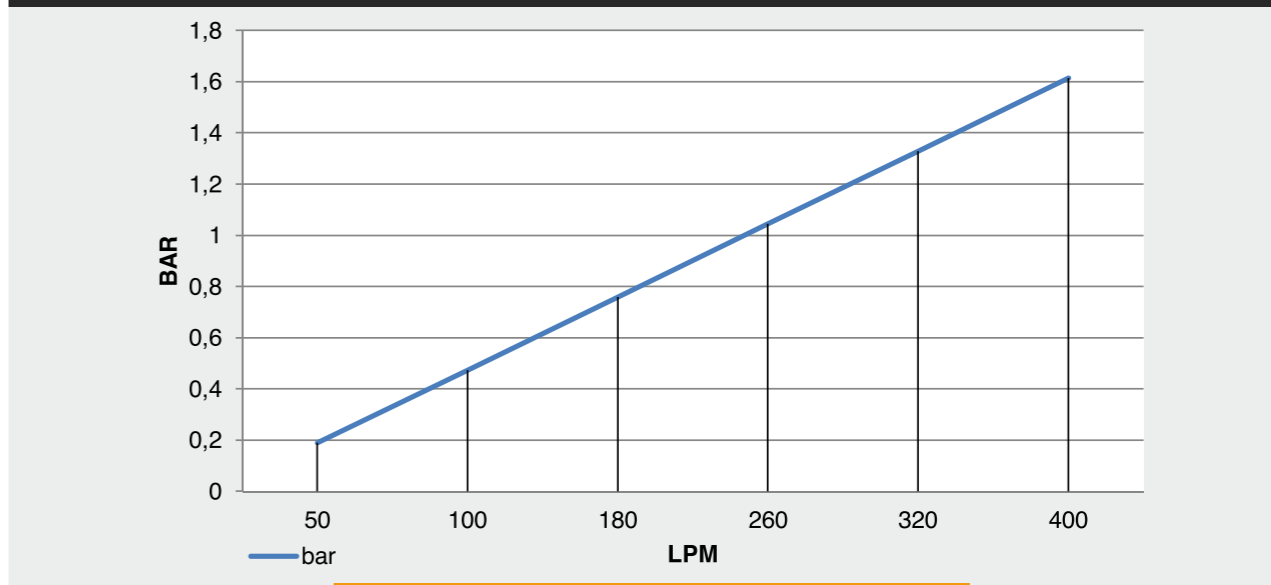
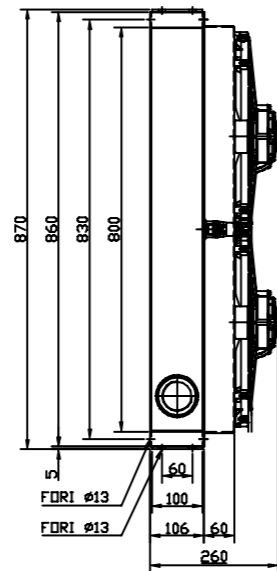
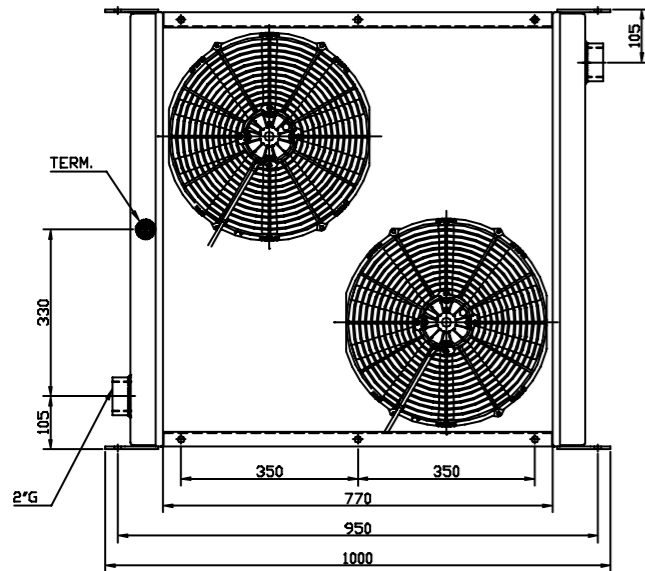

Vcc

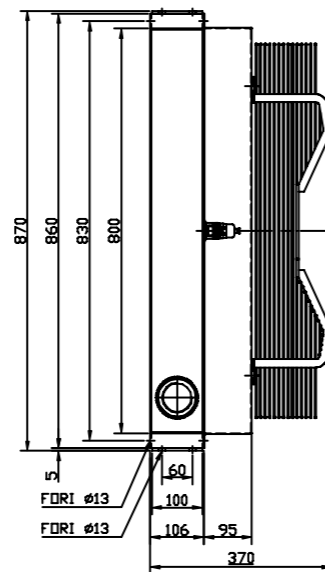
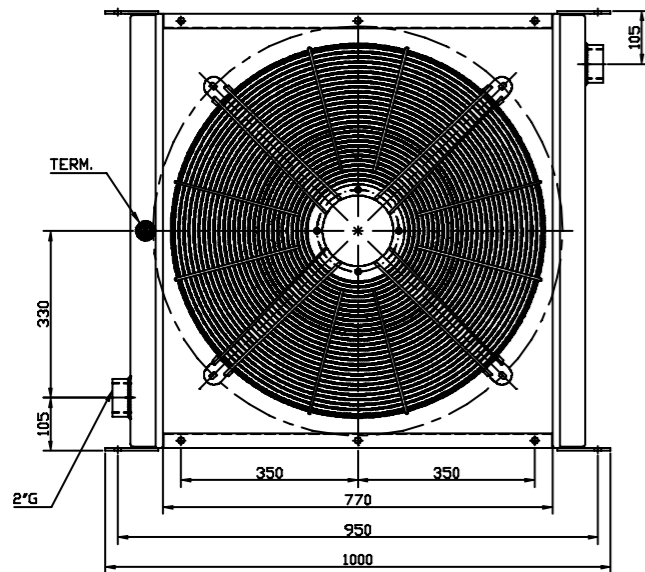

Vac

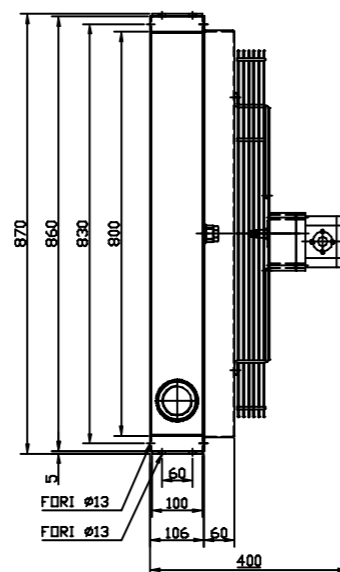
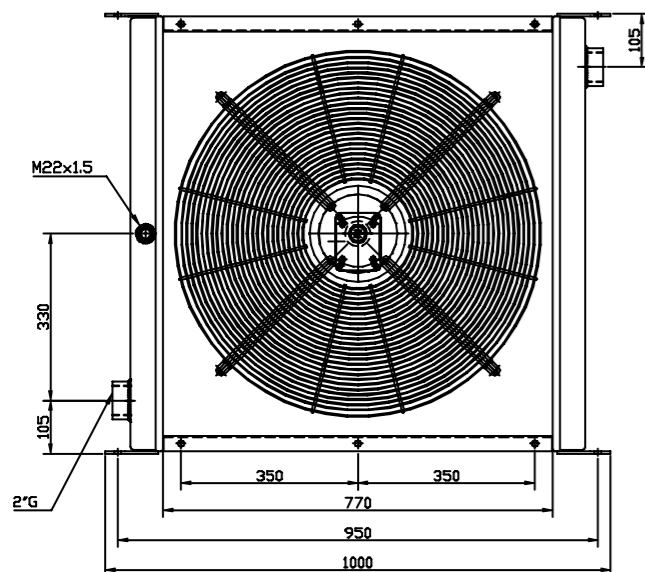

GR2

DATI TECNICI - TECHNICAL DATA

TENSIONE VOLTAGE	ASSORBIMENTO CURRENT	PORTATA ARIA AIR FLOW	PROTEZIONE PROTECTION	Ø
V	A	m ³ /h	IP	mm
12	18,1 x 2	3220 x 2	68	385 x 2
24	8 x 2	3080 x 2	68	385 x 2
230 Hz 50/60	3,9	11000	55	710
400/400 Hz 50/60	2,35 / 2,87	13950 / 17000	54	710
Predisposizione GR2 - Prepared for GR2			/	700

DIAGRAMMA DI RENDIMENTO - PERFORMANCE DIAGRAM



DIAGRAMMA PERDITE DI CARICO - PRESSURE DROP DIAGRAM



Portata olio - Oil flow: 50-500 lt/1'

CONDIZIONI GENERALI DI GARANZIA

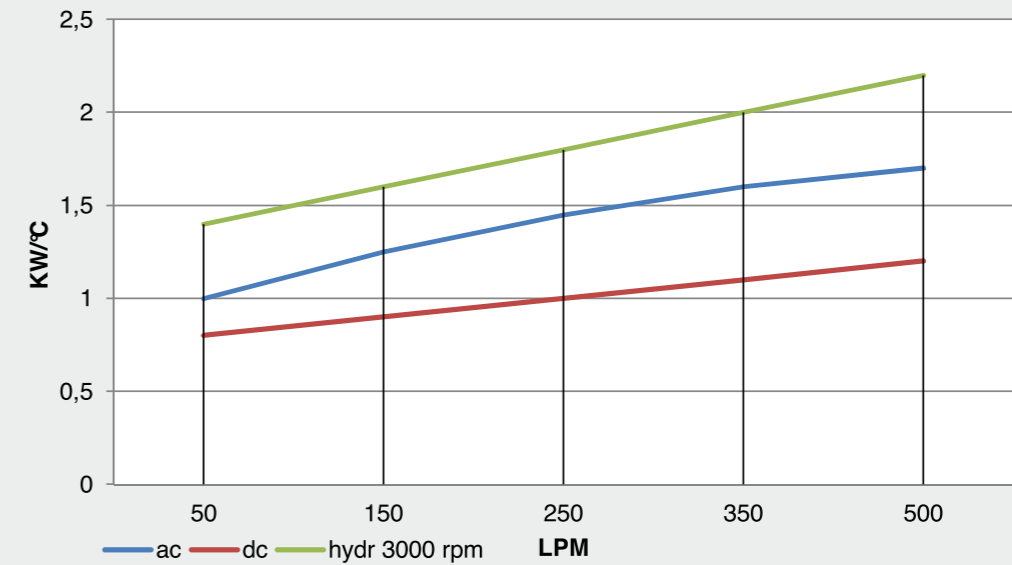
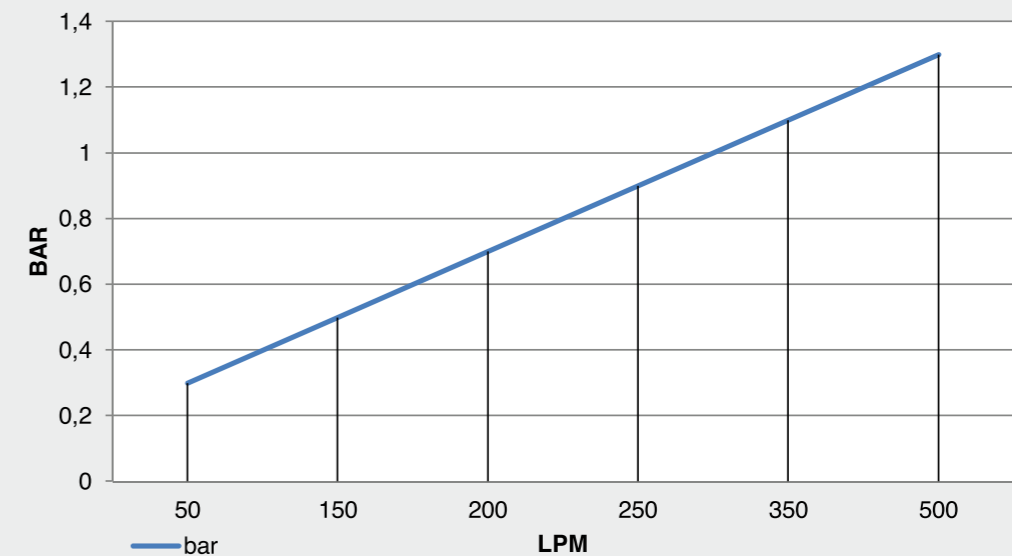
Le condizioni generali possono essere aggiornate e/o modificate in qualsiasi momento da IRA RADIATORI Engineering Srl, che provvederà a darne comunicazione nell'apposito spazio dedicato alle comunicazioni per i clienti (news, newsletter, circolari, cataloghi, sito web, ecc.).

Al fine di ottimizzare il servizio in termini d'efficienza nella gestione dei prodotti in garanzia, preghiamo la spettabile Clientela di osservare attentamente le seguenti procedure.

1. CONDIZIONI

- 1.1. Tutti i prodotti sono garantiti per 12 (dodici) mesi dalla data di acquisto comprovata dalla Ns. fattura di vendita, relativo D.D.T. (Documento di Trasporto) o ricevuta fiscale.
- 1.2 I prodotti di IRA RADIATORI Engineering sono garantiti per difetti di fabbricazione.
- 1.3 La garanzia consiste nella sostituzione o riparazione gratuita del componente ritenuto difettoso dal ns. settore tecnico.
- 1.4 Non sono considerati difetti di fabbricazione i danni subiti dal materiale durante il trasporto; la domanda di risarcimento per danni di questa natura deve essere rivolta esclusivamente al trasportatore o a chi si è occupato del trasporto, su autorizzazione del cliente.

2. TERMINI

- 2.1 La comunicazione di rilevato difetto o non conformità da parte del cliente, deve essere tempestivamente comunicata a IRA RADIATORI Engineering.
- 2.2 Previa autorizzazione da parte di IRA RADIATORI Engineering, il prodotto ritenuto difettoso o non conforme deve essere reso imballato in modo idoneo al tipo di trasporto scelto. Le spese di trasporto per la restituzione del materiale a IRA RADIATORI Engineering sono a carico del cliente.
- 2.3 Il reso del materiale deve essere accompagnato da regolare Documento di Trasporto e relazione esplicativa su quanto rilevato.
- 2.4 Il materiale verrà sottoposto da IRA RADIATORI Engineering a regolare collaudo, che stabilirà la tipologia e la causa del danno o non conformità.
- 2.5 IRA RADIATORI Engineering redigerà dettagliata relazione sul collaudo.
- 2.6 Se il danno o non conformità rilevata è da imputarsi a difetto di fabbricazione, il prodotto verrà riparato o sostituito con uno uguale o simile, a seconda della disponibilità di magazzino del momento. Le spese di trasporto saranno a carico di

IRA RADIATORI Engineering.

- 2.7 Se il danno o non conformità rilevata è da imputarsi a utilizzo o installazione errata del prodotto, verrà data immediata comunicazione al cliente e verrà redatta offerta per il ripristino del prodotto.
- 2.8 Nel caso in cui il cliente rifiuti l'offerta per il ripristino del prodotto, questo verrà rispedito al cliente, nello stato in cui si trova. Le spese di trasporto saranno a carico del cliente.
- 2.9 Nel caso in cui il cliente accetti l'offerta per il ripristino del prodotto, questo verrà ripristinato e rispedito al cliente, le spese di trasporto saranno a carico del cliente.

3. CONDIZIONI PARTICOLARI

- 3.1 Nel caso il cliente rilevi un difetto o non conformità del prodotto acquistato, ma non disponga del tempo necessario per svolgere la prassi sopra descritta, a causa della Sua necessità di utilizzare il materiale il prima possibile, può chiedere a IRA RADIATORI Engineering l'autorizzazione ad eseguire le lavorazioni necessarie per il ripristino del prodotto. La richiesta dovrà essere corredata di relazione dettagliata sul danno o non conformità rilevata, fotografie che evidenzino in modo chiaro la problematica e dettaglio dei costi necessari per il ripristino.

4. ESCLUSIONI

Sono esclusi dalla garanzia:

- 4.1 I prodotti il cui difetto è stato provocato da errata alimentazione, installazione e/o utilizzi non appropriati.
- 4.2 I prodotti risultati manomessi o con le etichette, che ne identificano il codice, rimosse, alterate o danneggiate.
- 4.3 Prodotti che presentano qualsiasi genere di manomissione, apertura o intervento sull'applicazione del prodotto o dei suoi componenti, anche nel tentativo di effettuare riparazioni o modifiche.
- 4.4 Danni derivanti da una non adeguata, periodica manutenzione.

I modelli illustrati nel presente catalogo sono stati collaudati con olio idraulico di viscosità 46 cSt a una temperatura di 60°C.

Le caratteristiche tecniche e le dimensioni illustrate nelle seguenti schede non sono impegnative e IRA RADIATORI Engineering si riserva il diritto di apportare le modifiche necessarie senza preavviso. Scostamento rispetto ai dati +/-5%.

GENERAL WARRANTY CONDITIONS

The general conditions may be updated and/or modified at any time by IRA RADIATORI Engineering Srl, who shall arrange for notification to be given in the special customer communication area (news, newsletters, circulars, catalogues, website etc.). In order to optimize the service in terms of efficiency in handling products under guarantee, customers are kindly asked to carefully observe the following procedures.

1. CONDITIONS

- 1.1. All products are under guarantee for 12 (twelve) months from the date of purchase, attested by our sales invoice, relative delivery note or receipt.
- 1.2 IRA RADIATORI Engineering products are guaranteed against defects in workmanship.
- 1.3 The warranty consists in the free replacement or repair of the component found to be defective by our technical department.
- 1.4 Damages to material incurred during transport are not considered defects in workmanship; compensation claims for damages of this nature must only be made to the haulage contractor or whosoever dealt with transport, on the customer's authorisation.

2. TERMS

- 2.1 IRA RADIATORI Engineering must be duly informed of any defect or non-compliance found by the customer.
- 2.2 Subject to authorisation on the part of IRA RADIATORI Engineering, the product found to be defective or non-compliant must be suitably packed according to the type of transport chosen. Shipping costs for returning material to IRA RADIATORI Engineering shall be borne by the customer.
- 2.3 Returns must be accompanied with a regular delivery note and an explanatory report on the findings.
- 2.4 The material will undergo regular testing, which will establish the type and cause of the defect or non-compliance.
- 2.5 IRA RADIATORI Engineering shall draw up a detailed report on the test.
- 2.6 Should the defect or non-compliance be due to poor workmanship, the product shall be repaired or replaced with an identical or similar one, according to current stock availability. Shipping costs shall be borne by IRA RADIATORI Engineering.

ring.

- 2.7 If the fault or non-compliance is found to be due to the incorrect use or installation of the product, the customer shall be informed immediately and an estimate for product repair shall be drafted.
- 2.8 Should the customer refuse the product repair quote, the product will be sent back to the customer, in the condition it is in. Shipping costs shall be borne by the customer.
- 2.9 Should the customer accept the product repair quote, it will be repaired and sent back to the customer, shipping costs shall be borne by the customer.

3. SPECIAL CONDITIONS

- 3.1 In the event that the customer finds a defect or non-compliance in the product purchased, but does not have the time to carry out the aforementioned procedure due to the fact that he/she needs to use the material as soon as possible, he/she can ask IRA RADIATORI Engineering to authorise the carrying out of the procedures necessary to repair the product. The request must be furnished with a detailed report of the damage or non-compliance found, photographs which clearly highlight the problem and details of the necessary repair costs.

4. EXCEPTIONS

The following are excluded from the warranty:

- 4.1 Product damage caused by incorrect power supply, installation and/or inappropriate use.
- 4.2 Products which prove to have been tampered with or whose identificatory code label has been removed, altered or damaged.
- 4.3 Products which display any kind of tampering, opening or interference on the application of the product or its components, also due to attempted repair or modification.
- 4.4 Damage ensuing from inadequate, periodic maintenance.

All the described models in this catalogue have been tested under the following operating conditions: Oil viscosity 45 cSt with temperature 60°C. The specifications and dimensions indicated in following data sheets are not binding: IRA RADIATORI Engineering, therefore, reserves the right to make changes at any time (variance +/- 5%)